

Easy. Scalable. Quality.

Garland Technology

Providing the Visibility Foundation

Network Administrators and SecOps team need to ensure that the data being fed into their analytic and security tools is complete and accurate.

Garland Technology specializes in providing the products needed to deliver every “bit, byte & packet” to the monitoring and security tools, on-prem or in the cloud.



Garland Technology is Global



3,000 customers and 100 partners globally

New York | Texas | UK | Poland | Australia



Deployed in every vertical



- Telcos •Government •Healthcare •Defense •Manufacturing
- Financial •Retail •Energy •Entertainment •Technology Pharmaceuticals
- Education •Transportation
- Gaming •Any enterprise IT network

Who Has Gained Visibiliy with Garland?

Financial / Insurance



Telecom



Government



Major Brands



Manufacturing



Healthcare



It starts with the Packet

- **Complete Visibility Truth**, passing all live wire data
- **Guaranteed 100% Uptime** for active, inline security tools
- **Ensure No Packets Loss**, for out-of-band tools
- **Flexible Cloud Packet** access

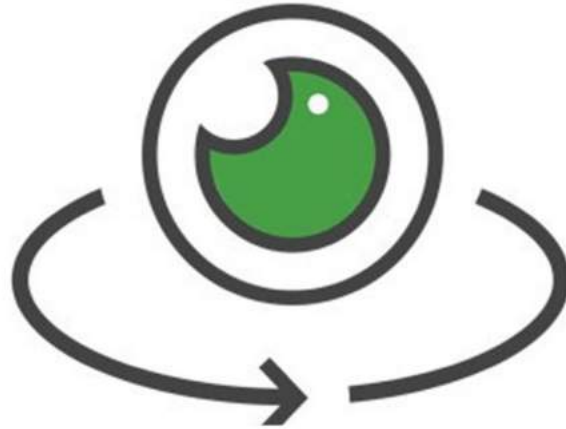

- **Optimize** your security and monitoring tools
- **Maximize** and enhance your existing infrastructure
- **Easily upgrade** existing speeds, save on new tools
- **Easy migration** to Private and Public Cloud

360° Visibility

Network Visibility Provides

Awareness of:

- + Everything connected to the network
- + Everything flowing through and into the network

Benefits include:

- + Improved Network & Application performance
- + Reduced troubleshooting time & cost
- + Identification of malicious behavior and potential threats
- + Regulatory compliance
- + Successful business transformation



360°

Network Visibility Fabric

Starts with Garland Technology



Physical Layer TAPS

- 100% visibility for out-of-band monitoring tools
- Continues development (First to release OM5, customized solutions)



Purpose-built Packet Brokers

- Aggregation layer supports filtering, aggregation and load balancing
- Advanced features support deduplication, packet slicing, time stamping and more



Inline Edge Security

- Reduce the risk of downtime
- Adds resiliency and peace of mind
- Innovative inline hybrid packet broker



Cloud

- Private

Network Visibility Fabric

«You Can't Troubleshoot or Protect What You Can't See or Manage»

+ Two components

- + Out-of-Band network infrastructure

 - + Provides packet level visibility for monitoring appliances

 - + Invisible, non-disruptive and secure method of mirroring packets from accross the network to monitoring and security tools (IDS etc)

- + In-Line infrastructure

 - + Inline tool connection method

 - + Protects the network, reduces operational burden and costs and improves the effectiveness of in-line security tools (NGFW, IPS etc.)

Scalable Visibility Fabric For Your Architecture

Eliminate network and security blind spots, while adding resiliency and high performance for both inline and out-of-band environments

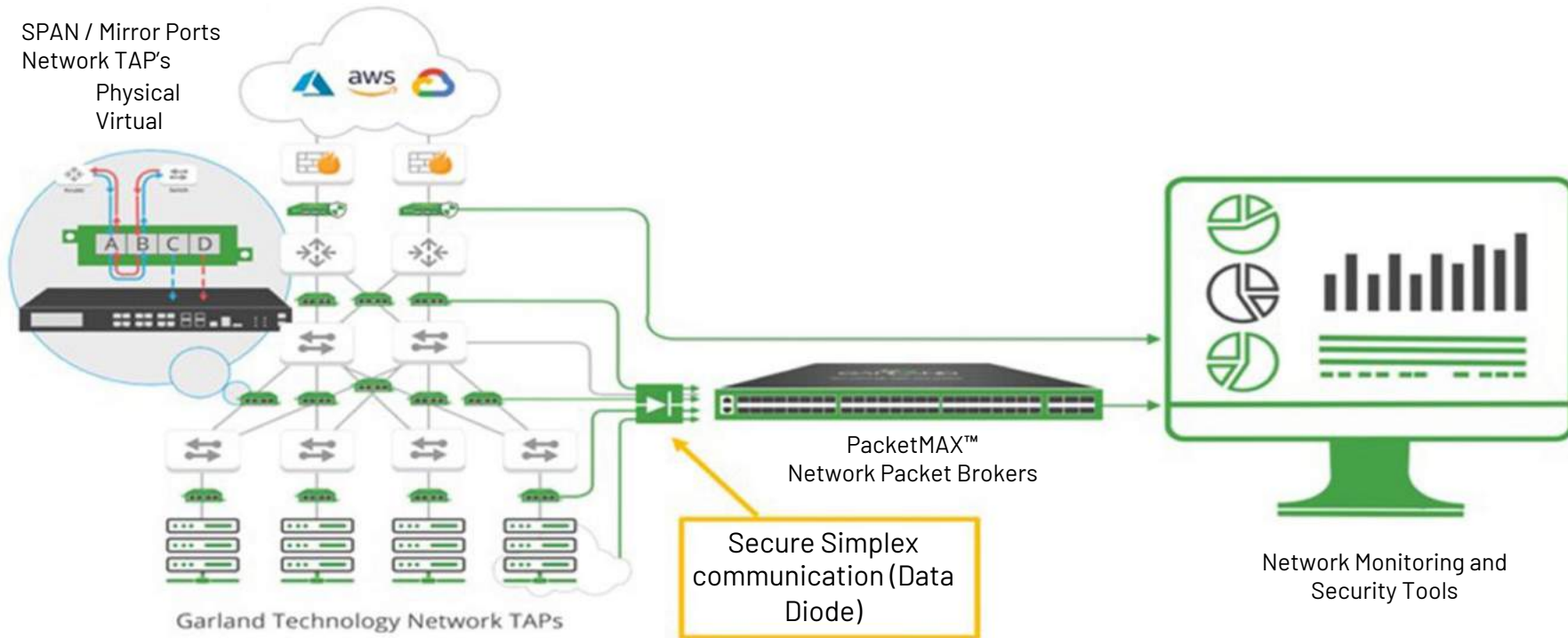

Scalable Visibility Fabric For Your Architecture

Eliminate network and security blind spots, while adding resiliency and high performance for both inline and out-of-band environments

Out-of-Band / Passive

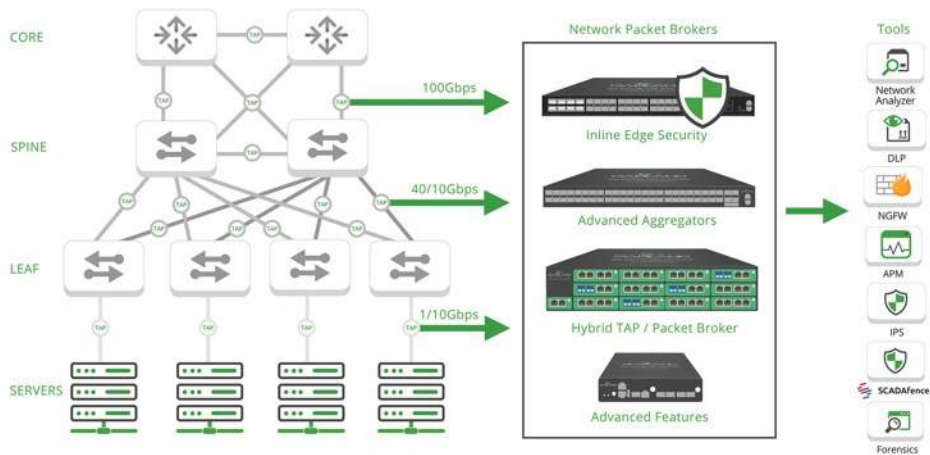

Inline / Active

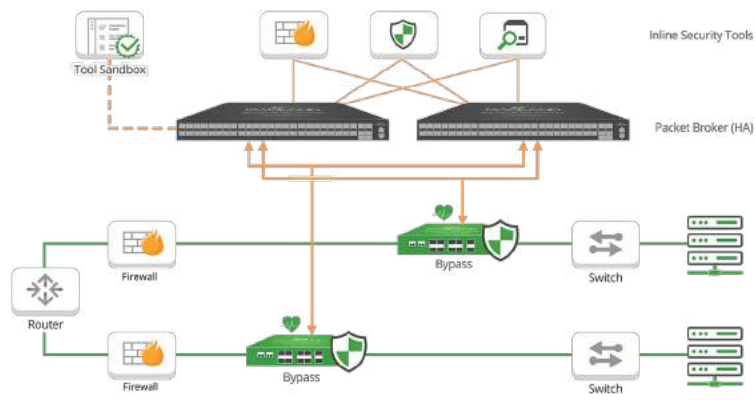

Technology Partnerships

Our TAP to Tool™ philosophy empowers the solution by architecting to the tool



How Garland Technology Works with Your Monitoring Solutions?

Deploying of managing
One of these tools?



Work with any
of these companies?



Recommended Garland Products



Breakout Network TAPs

- Passive Fiber & Copper



Aggregator Network TAPs

- Universal TAPs



Xr-tra TAPs

- All-in-1 Advanced TAP

Network Packet Brokers



Advanced Aggregators

High Density filtering aggregation and load balancing

Advanced Features

- DeDup, time stamping



Hybrid NPB System

- Inline Security

How Garland Technology Works with Your Monitoring Solutions?

Deploying of managing One of these tools?



NGFW



WAF



IPS



DDoS



DLP



SSL Decryptor



Packet
Capture



Packet
Injection

Work with any of these companies?

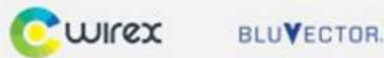

Recommended Garland Products



EdgeSafe: Bypass TAPs

- Fallsafe & heartbeat technology
- 1G/10G/40G/



* EdgeLens In-line Security

- Hibrit Packet Broker



Network Packet Brokers

Advanced Aggregators

High Density filtering aggregation and load balancing

Advanced Features

- DeDup, time stamping



• Hybrid NPB System

- Under 200 Ports

Portfolio

«You Can't Troubleshoot or Protect What You Can't See or Manage»



**Hybrid
TAP/Packet
Brokers**

Network Packet Brokers



**Hybrid Inline
Packet Broker**



Network TAP's



Virtual TAP's



Inline Bypass

Network TAPs



Provide Complete Visibility for High-Performance Monitoring Solutions

- Purpose-built for packet visibility
- Can mirror 100% full duplex traffic
- 100% secure, can't be hacked
- Passive or Active with failsafe, doesn't impact network operation

100% Secure and Complete Visibility

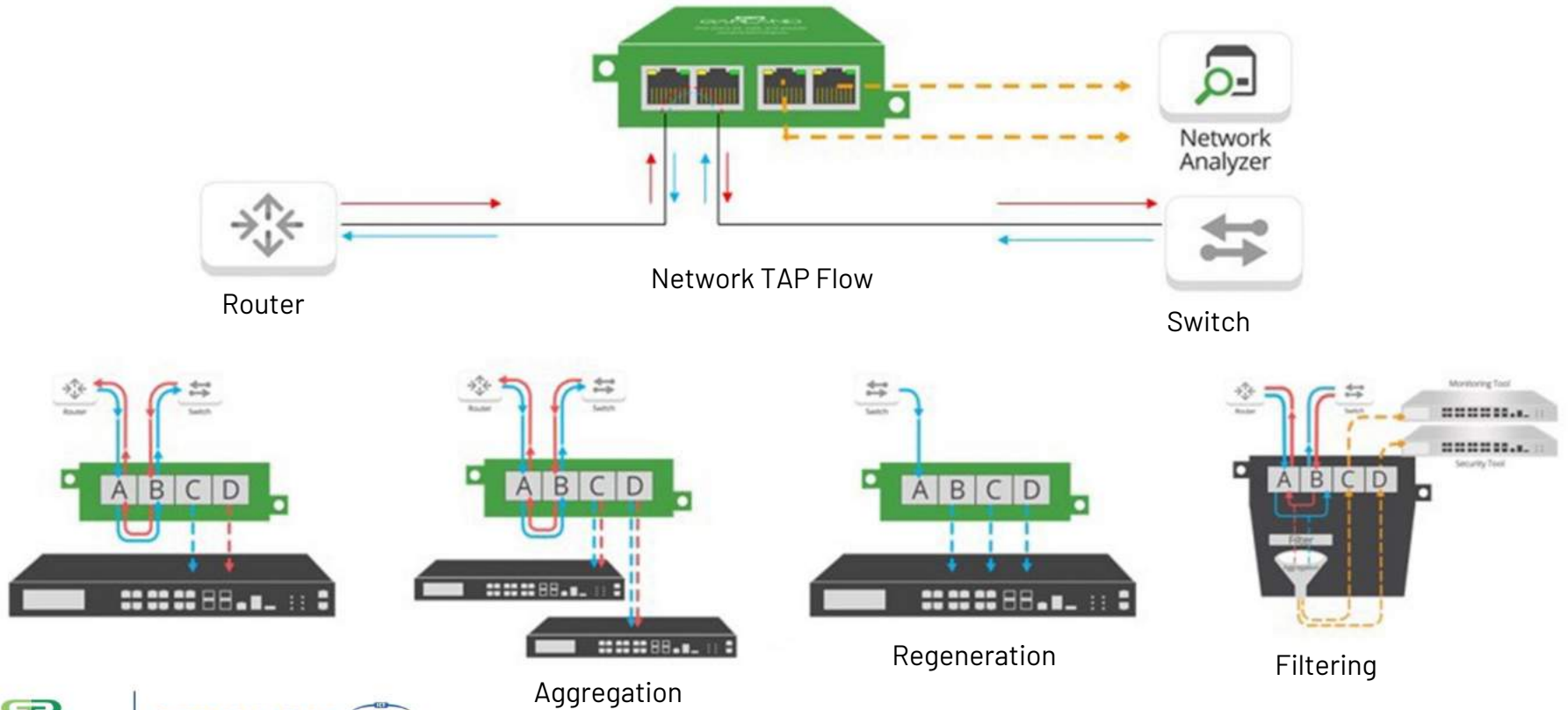

Media Conversion

+ Media Conversion with Network TAPs

- + Media Conversion from SX and LX fiber to RJ45 copper or SF
- + Media Conversion from 100 Base-FX and 100 Base-LX to RJ45 copper
- + Media Conversion from SR and LR to SFP+ (Copper, SR or LR)

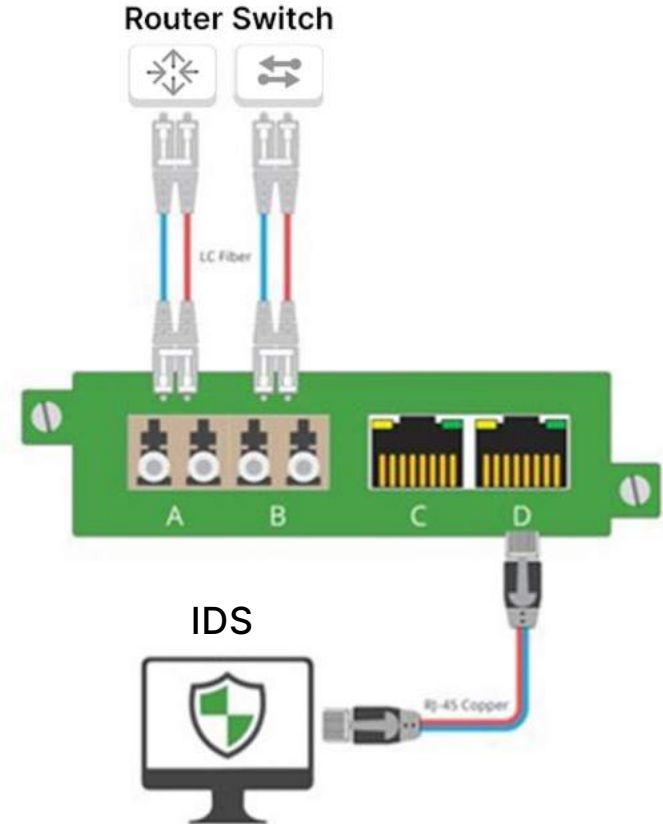

Secure Simplex Mirroring

+ **Avoiding security vulnerabilities**

- + Network TAP's have no MAC address that can be accessed through the network ports
- + Data Diode (Simplex) Network TAP's guarantee data (malicious or other) can never be injected into the operational network
- + SPAN/Mirror ports on switches&routers expose a security vulnerability-they have a Receive as well as a Transmit ability

Data Diode TAPs

Secure One-Way (Simplex) Traffic

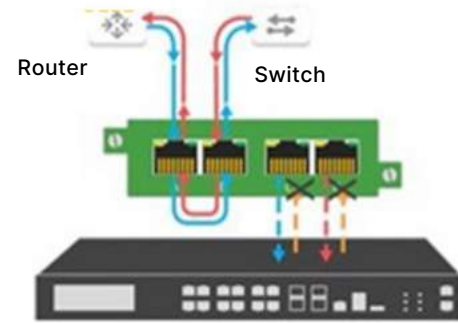
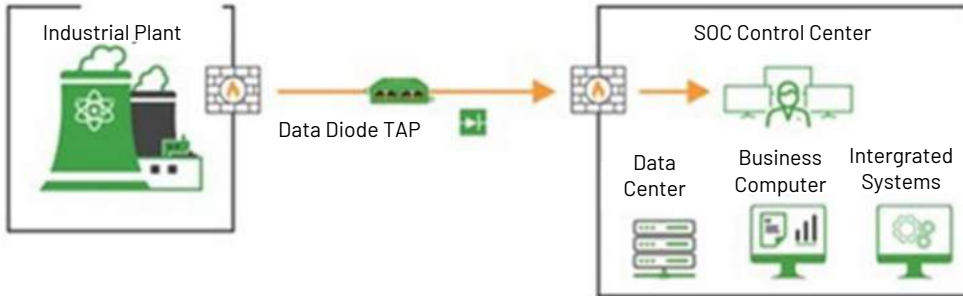
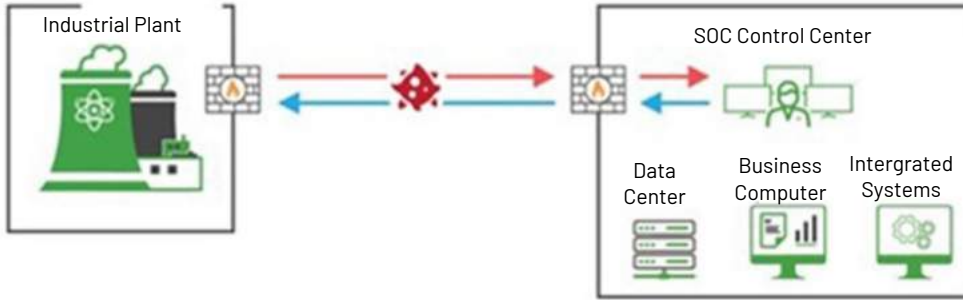

Data Diode Network TAP

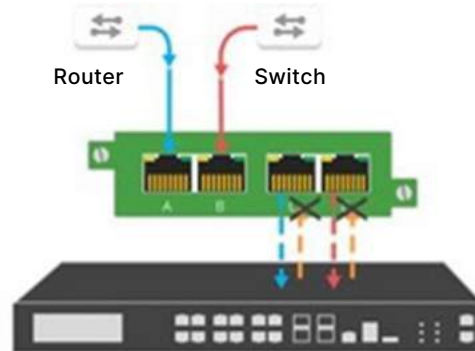

Data Diode SPAN TAP

Garland Technology Data Diode TAP's

+ Passive Fiber TAPs

- + Utilise optical splice technology which blocks incoming data (light) on the monitor ports
- + Prevents data (traffic) being injected from the monitor ports into the network

+ Passive Copper TAP's

- + Monitor ports have no physical RX connection

+ Active Copper & Fibre TAP's

- + Monitor ports have no physical RX connection
- + Exception
- + Bypass or TAP2s specifying data insertion ability

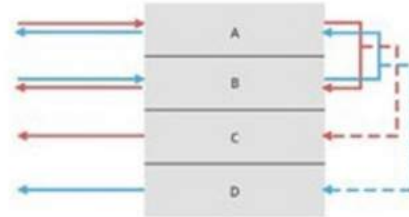
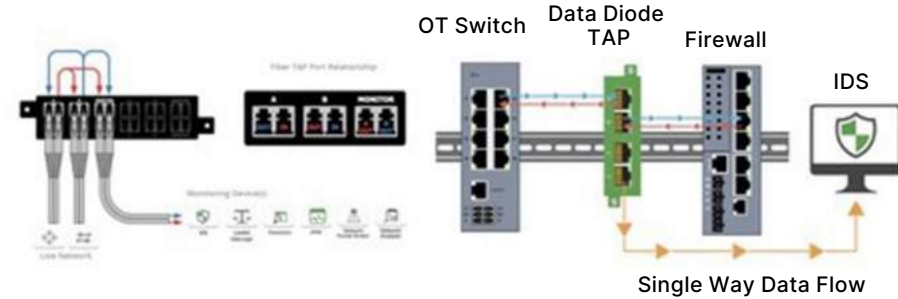

This diagram depicts 4 port (A,B,C,D). The Data Diode Network TAP shows port A flow out port B and sends a copy out of port C and Port B flow out of Port A and sends a copy out port d.

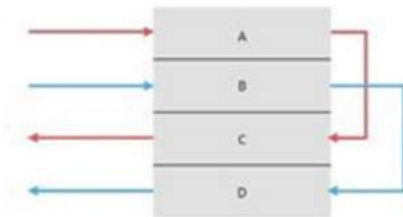

This diagram depicts 4 port (A,B,C,D). The Data Diode SPAN TAP shows the traffic of Port A flow out of port C and Port B flow out of port D.



Innovation



Performance
& Reliability



Highest
Quality

Network TAPS

Portfolio

+ Passive Fibre TAP's

- + Chasis, fixed 1U and Portable (1/4) options
- + 1G - 400G speed
- + MMF&SMF
- + OS1 & OS2
- + OM1, OM2, OM3, OM4 & OM5
- + LC, MPO/MTP connectors
- + Breakout & Regeneration, BiDi
- + Data Diode Design

+ Passive Copper Breakout TAP

- + Portable (1/4) form factor
- + 10/100m
- + Breakout
- + Data Diode Design



Portfolio

+ Active TAP's

- + Chasis, 1U ½ width, Portable (1/4) and Field options
- + 100M, 1G ve 10G hız + Copper, MMF and SMF
- + USB, Mighty Mouse, RJ45, SFP, SFP+ and LC connectors
- + Breakout, Agregation & Regeneration options
- + Data Diode Design
- + LFP, LSS and PoE
- + Filtering

+ Industrial Accessories

- + DIN Rail mounting for portable TAPs
- + DC - DC convertor



Visibility for Specialized and Extreme Environments

From Extreme Temperatures, to Secure Rugged Connections



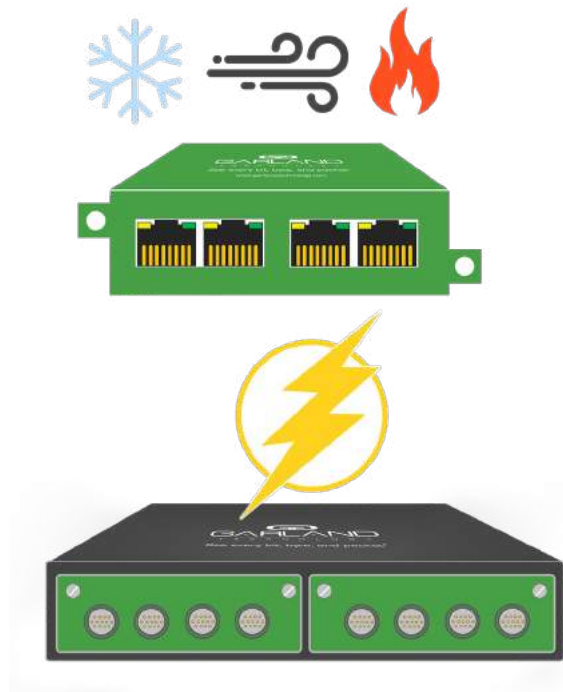

- Rugged metal construction
- Environmental durability: withstand exposure to corrosive, high-heat, and high-pressure weather environments.
 - TAPs Engineered for extreme temperature variations
-40C to +85C / -40F to +185F
- Designed to specific requirements to address electromagnetic interference (EMI).
- Secure connections and power connectors
 - Mighty Mouse connectors
 - Power Lock connectors



Data Diode Portfolio

One-way Traffic for Network Monitoring without Exposure to Additional Risk



Data Diode TAPs	Data Diode SPAN TAPs	Aggregator TAP: Data Diode	RegenTAP: Dual Breakout SPAN 1x4
			
10/100/1000M and 1G/10G	10/100/1000M	10/100/1000M	1G/10G
<ul style="list-style-type: none"> • Copper RJ45[n / m] • 100Base-FX [n] • Single Mode [n] • Multi Mode [n] • SFP [m] 	<ul style="list-style-type: none"> • Copper RJ45 [n] 	<ul style="list-style-type: none"> • Copper RJ45 [n] • SFP (m) 	<ul style="list-style-type: none"> • (10) SFP+
<ul style="list-style-type: none"> • Portable 	<ul style="list-style-type: none"> • Portable 	<ul style="list-style-type: none"> • % Rack 1U Chassis 	<ul style="list-style-type: none"> • % Rack 1U Chassis
<ul style="list-style-type: none"> • Protect network traffic • Undirectional traffic flow • Traffic control is enforced at the physical level 	<ul style="list-style-type: none"> • Protect SPAN port traffic • Undirectional traffic flow • Traffic control is enforced at the physical level 	<ul style="list-style-type: none"> • Protect network / SPAN traffic • Undirectional traffic flow • Traffic control is enforced at the physical level • TAP Aggregation 4x2 (8x1 SPAN) 	<ul style="list-style-type: none"> • Protect SPAN port traffic • Undirectional traffic flow • Ideal for direct connect, SFP, QSFP active cable infrastructures.

Virtual TAP

+ Visibility into Inter-host communication



- + Hypervisor Independent
- + Security Simplex
- + Support for:
 - + Windows Server 2019
 - + Linux via Docker
 - + Linux - Red Hat, Ubuntu, SUSE



Innovation



Performance
& Reliability



Highest Quality

Network Packet Brokers



OTD BİLİŞİM

GLOBAL VAD



Network Packet Brokers

+ Mechanism to aggregate, shape & direct monitored traffic to Tools

+ Reduce cost and complexity

- + Speed troubleshooting
- + Detect breaches faster
- + Reduce burden on security tools
- + Extend the life of monitoring tools
- + Support regulatory compliance

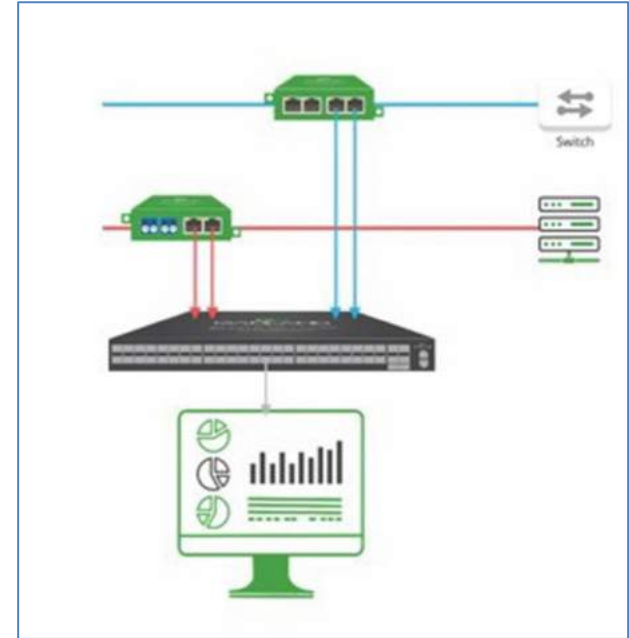

PacketMAX Packet Brokers

Support Your Packet Broker Need or Enhance Your Existing Infrastructure



- **Scalability and Flexibility:** Deploy what you need, when you need it. Modular solutions for future growth.
- **Simple:** With easy set management or by incorporating Restful API, put the focus on the tools.
- **Optimize your investment:** With better performance, protect and extend your current environment.
- **Open Vendor:** We support multi-source agreement (MSA) transceivers/optics, no vendor lock-in.
- **No licensing or port fees.**

Network Packet Brokers

+ Layered functionality

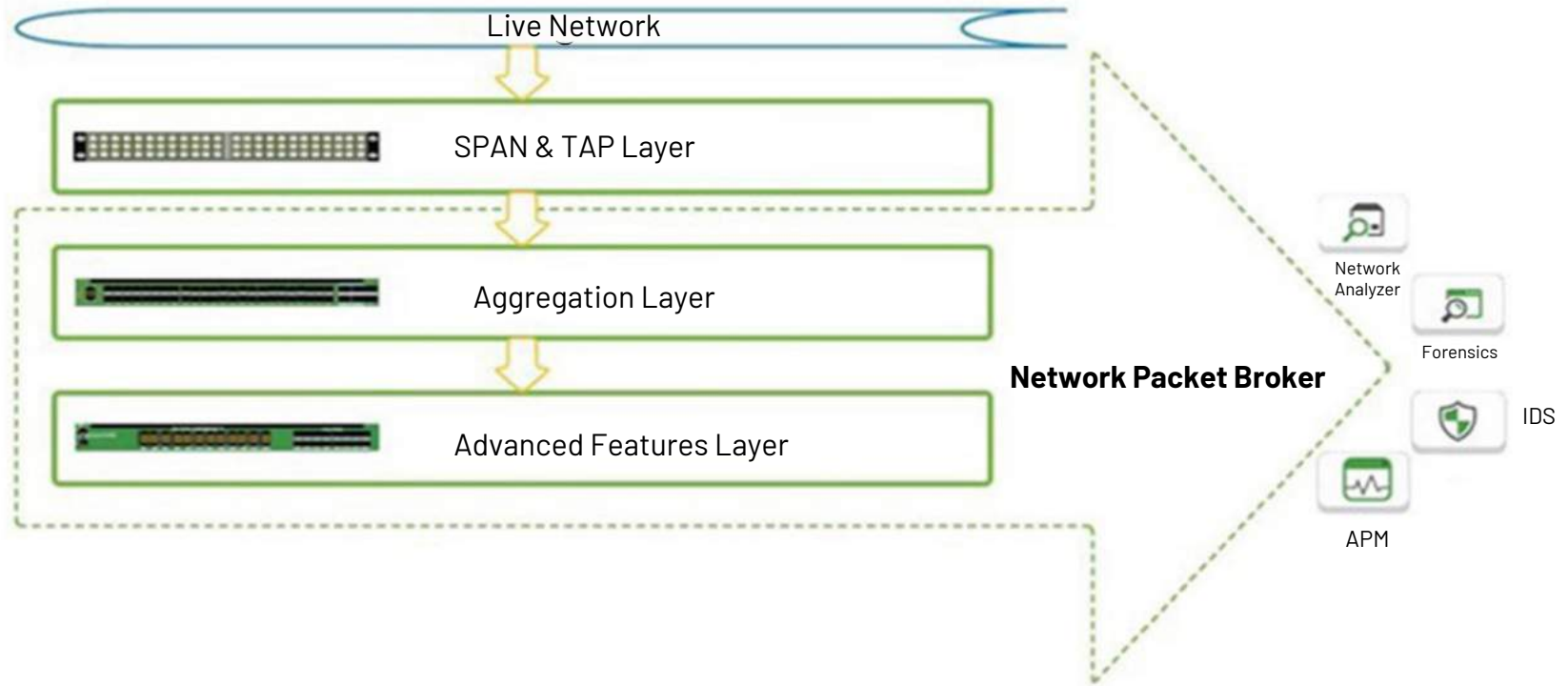

Network Packet Brokers

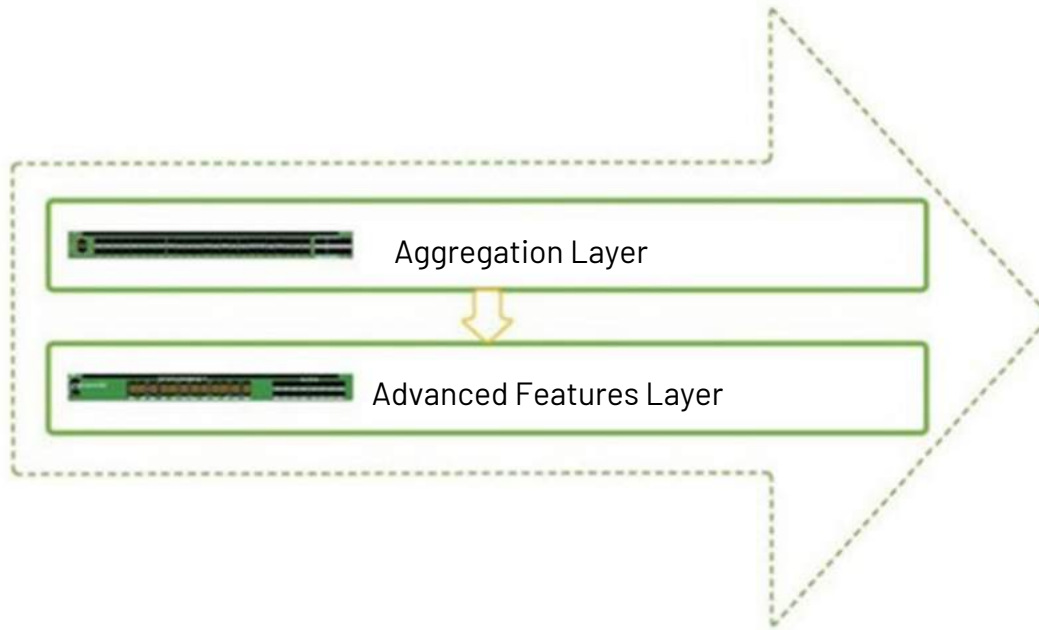

Aggregation & Regeneration – N to 1,1 ila N, N to N

Filtering- 2, 3 & 4

Loadbalancing- HASH, Round Robin etc.

Decapsulation - GRE, VXLAN, MPLS, VLAN,ERSPAN etc.

Tunneling Encapsulation- GRE, VXLAN

Packet Slicing- Payload removal - NTP, PTP

Deduplication – Multilevel analysis & removal of duplicates

Metadata Engine- IPFIX, Netflow generation

Application Seesion Filtering – User defined filters etc





Decryption- SSL decryption

Entegre TAP – Hybrid TAP/NPB

Inline Tool Connectivity – Fail safe, Heartbeats, load balancing, serial chaining

Network Packet Broker Portfolio





Deploy What You Need, When You Need It

PacketMAX™ Advanced Collector	PacketMAX™ Advanced Collector	PacketMAX™ Advanced Collector	PacketMAX™ % Rack 1U Chassis 1U Chassis
			
1G/10G/25G/40G/100G	1G/10G	1G/10G/40G/100G	1G/40G/100G
<ul style="list-style-type: none"> • RJ45 • SFP+ • QSFP+ • QSFP28 	<ul style="list-style-type: none"> • SFP+ 	<ul style="list-style-type: none"> • RJ45 • SFP+ • SFP28 • QSFP+ • QSFP28 	<ul style="list-style-type: none"> • SFP+ • QSFP+ • QSFP28
<ul style="list-style-type: none"> • 1U or 2 Chassis 	<ul style="list-style-type: none"> • % Rack 1U Chassis • 1U Chassis 	<ul style="list-style-type: none"> • 1U Chassis 	<ul style="list-style-type: none"> • 1U Chassis
<ul style="list-style-type: none"> • Reduce and optimize traffic to improve tool performance • Filtering, Aggregation and Load Balancing • Start and Terminate GRE and L2GRE Tunnels • 2k filters • No additional per-port license fees 	<ul style="list-style-type: none"> • Reduce and optimize traffic with a small form factor • Filtering, Aggregation and Load Balancing • 1U with Innovative 13" depth • No additional per-port license fees 	<ul style="list-style-type: none"> • Reduce and optimize traffic to improve tool performance • High density Filtering (Ingress&Egress), Aggregation and Load Balancing • Time stamping • Packet Slicing • GRE, ERSPAN, VxLAN, L2RE Encap / Decapsulation • VLAN Tagging, VLAN/MPLS stripping 	<ul style="list-style-type: none"> • Reduce and optimize traffic to improve team performance • Large window deduplication • FPGA Based design for increased flexibility • Time Stamping: 5 nS resolution • Programmable Packet Slicing

TAP Packet Broker Hybrid Portfolio

Deploy What You Need, When You Need It



XtraTAP™	XtraTAP™	XtraTAP™	XtraTAP™	XtraTAP™
				
10/100/1000M	1/10G	1G/10G	1G/10G	40G
<ul style="list-style-type: none"> • Copper RJ45 [n / m] • Single Mode [n] • Multi Mode [n] • SFP [m] • 1U or 2U Modular Chassis 	<ul style="list-style-type: none"> • Single Mode [n] • Multi Mode [n] • SFP+ [m] 	<ul style="list-style-type: none"> • Single Mode [n] • Multi Mode [n] • SFP+ [m] 	<ul style="list-style-type: none"> • Single Mode [n] • Multi Mode [n] • SFP+ [m] 	<ul style="list-style-type: none"> • SR4 [n] • LR4 [n] • SFP+ / QSFP+ [m]
<ul style="list-style-type: none"> • 1U or 2U Modular Chassis 	<ul style="list-style-type: none"> • Portable 	<ul style="list-style-type: none"> • Portable 	<ul style="list-style-type: none"> • High Density 1U Chassis 	<ul style="list-style-type: none"> • High Density 1U Chassis
<ul style="list-style-type: none"> • TAP with packet broker features • Supports filtering, aggregation, bypass or breakout TAP modules • FailSafe • Multi-Tier Filtering supports MAC, VLAN, IP, DSCP, TCP, UDP 	<ul style="list-style-type: none"> • TAP with packet broker features • Provide 100% full duplex traffic visibility • Advanced filtering for layer 2, layer 3 and layer 4 • Supports tap filtering, «breakout», aggregation and regen modes 	<ul style="list-style-type: none"> • Portable packet broker: • Four port SFP+ design • Ultimate flexibility: Configure TAP modes, ports, speeds and media • Advanced filtering for layer 2, layer 3 and layer 4 	<ul style="list-style-type: none"> • TAP + packet broker features in 1 • Provide 100% full duplex traffic visibility • Filtering, Aggregation and load balancing • Hardware base chaining • Remote mnngt 	<ul style="list-style-type: none"> • TAP + packet broker features in 1 • Provide 100% full duplex traffic visibility • Filtering, Aggregation and load balancing • Hardware base chaining • Remote mnngt

TAPs

VS

SPAN

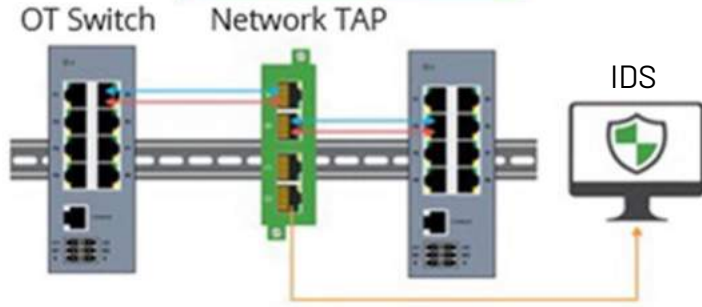

- Ensures no dropped packets, passing physical errors and supports Jumbo frames
- Does not alter the time relationships of frames
- Passive or failsafe, ensuring no single point or failure (SPOF)
- Data Diode TAPs provide unidirectional traffic to protect against back flow of traffic into the network
- TAPs are secure, do not have an IP address or MAC address and cannot be hacked

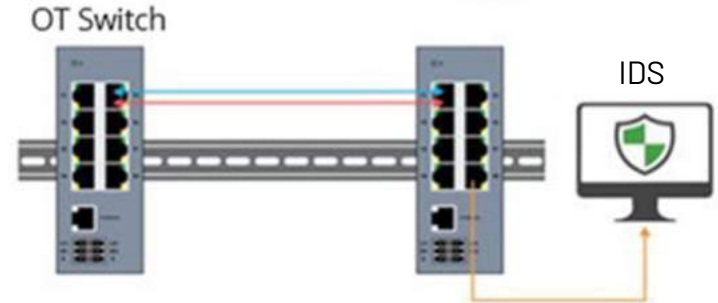

- Can take up high value ports on the switch
- Some legacy switches do not have SPAN available
- SPAN ports can drop packets
- Will not pass corrupt packets or errors
- Bidirectional traffic opens back flow of traffic into the network, making switch susceptible to hacking
- Administration/programming costs for SPAN can get progressively more time intensive and costly

Two Ways to Mirror Traffic

TAP

- Does not drop packets, regardless of bandwidth
- Plug & Play, set-up once and never touch again
- Does not alter the time relationships of frames
- Does not impact the live network while monitoring

SPAN

- Packets are dropped when ports are oversubscribed
- Easily misconfigured or turned off
- Can change the timing of the frame interactions
- Degrades performance of live network

The EDGE
of the Network is Green

From the Inventor of Bypass Technology



Edge / Remote
Locations



Data Center



Enterprise

How to Improve IT Security Threat Detection and Prevention Deployments?

Implementing Inline Visibility Architecture

Inline Edge Security Deployments

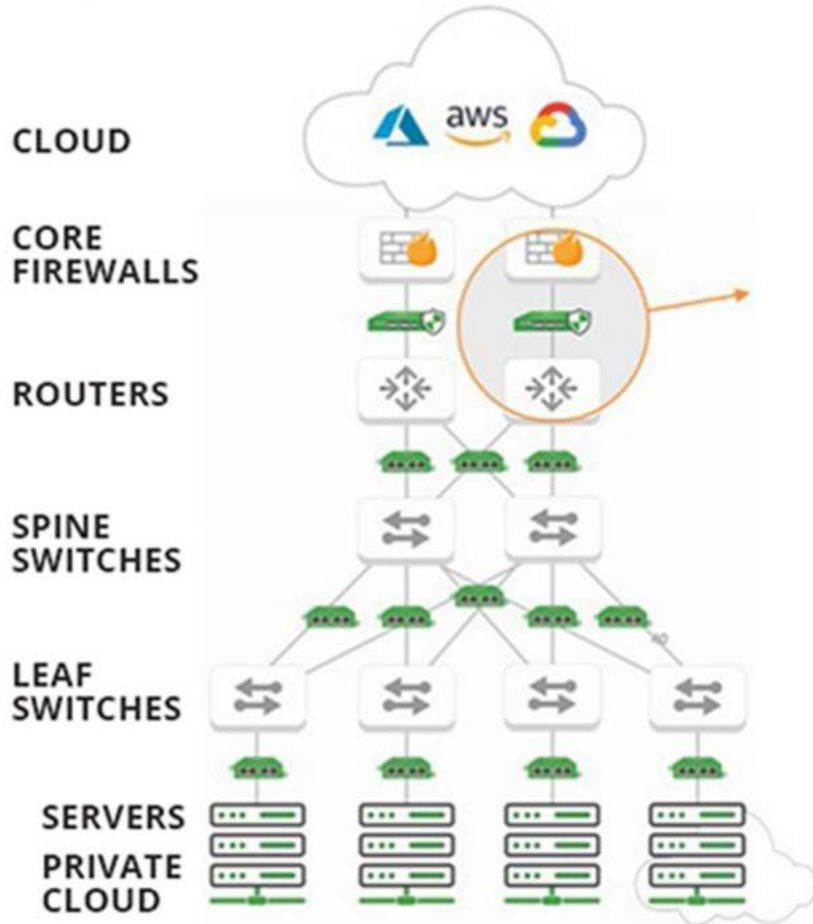

Inline Bypass TAP's



Managing Multiple Tools



Benefits of Inline Bypass

Deploying and Managing Your Inline Appliance

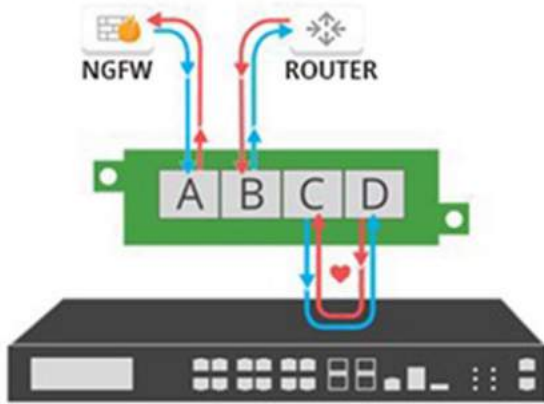

Inline Bypass

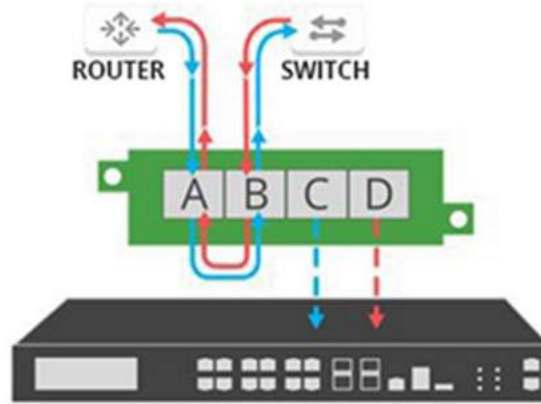

Out-of-Band Tap 'Breakout'

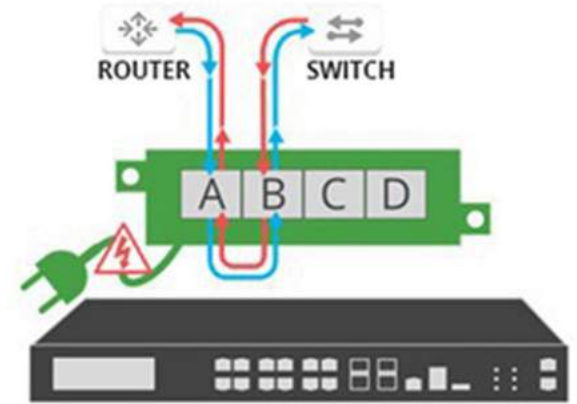

Failsafe

- No maintenance Windows – Peace of mind without network downtime.
- Operational – Expedited problem resolution of unplanned downtime.
- Network resilience – flexibility to bypass the tool and keep the network up, or Failover to HA solution.

Reduce Network Downtime

IT Security Solutions Use Case

Challenge: Managing the risk of downtime is a critical consideration when deploying security tools.

- Oversubscribed devices, degrade network performance
- Device failures can bring down the network
- Deploying new Technologies into the network
- Scheduling off hour planned downtime

Solution: Bypass TAP "Inline lifecycle management" allows to you:

- Easily take tools out-of-band for updates, installing patches, maintenance or troubleshooting to optimize and validate
- Administrative isolation – No maintenance windows
- Tool Sandbox – Pilot or deploy new tools

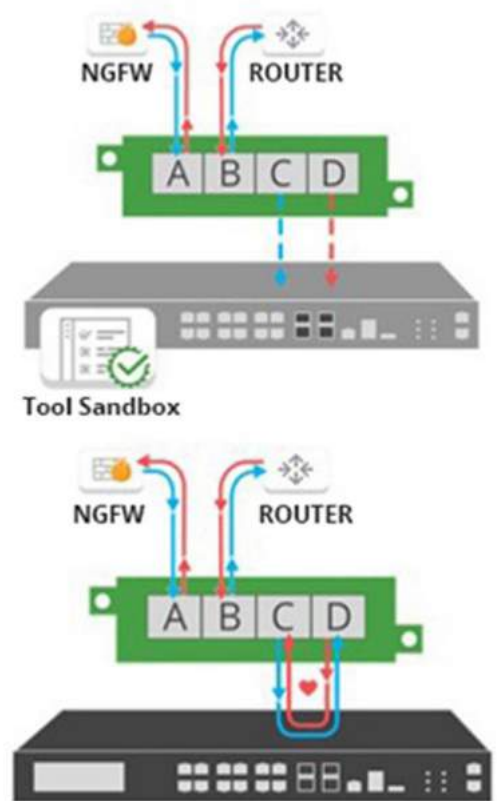

Eliminate Single Points of Failure

IT Security Solutions Use Case

Challenge: Because inline tools (IPS, firewalls) sit in the live network, the challenge of deploying these tools is to not create a possible single point of failure (SPOF) in the process.

Solution: Bypass TAPs provide the ability to manage your inline tool any time without having to take down the network or impact business availability for maintenance or upgrades – ensuring this inline security tool is not a point of failure in the network:

- Failsafe deployment of inline tools
- Configurable security tool heartbeats
- Eliminates single points of failure within your network
- No maintenance windows

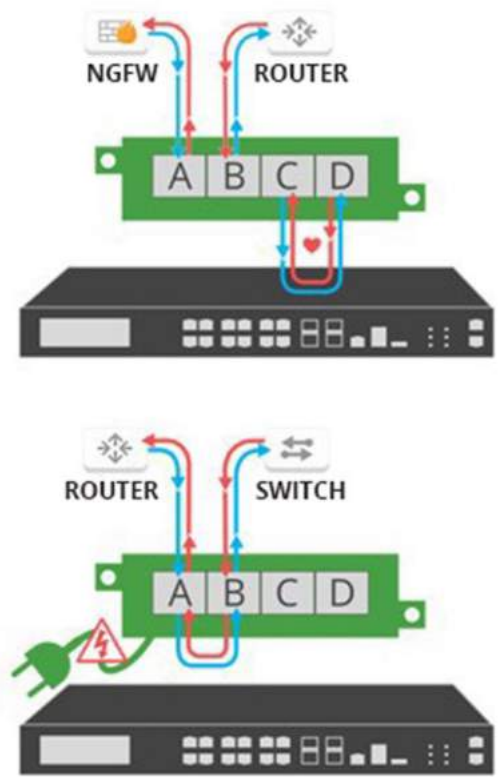

Inline Lifecycle Management

Manage Your Inline Tool Any Time without Having to Take Down the Network

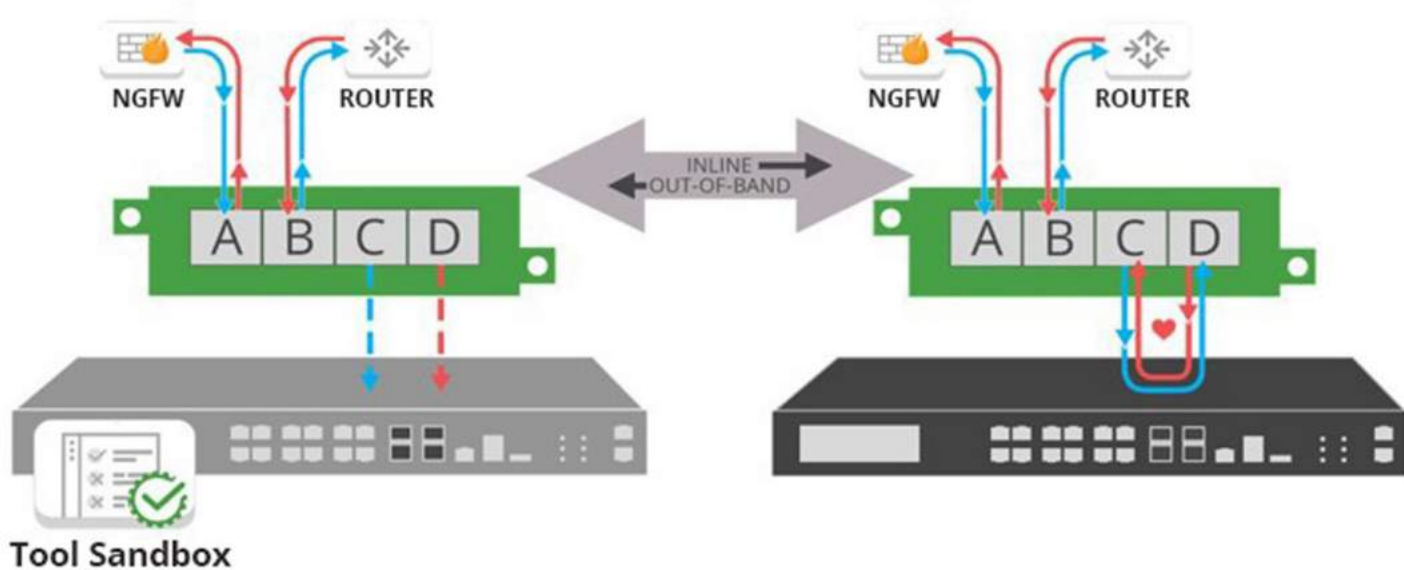

- Tool Sandbox – Pilot or deploy new tools
- Evaluate & Optimize the tool out-of-band
- Validation push active inline
- Troubleshooting & Maintenance

Managing Multiple Inline Tools

IT Security Solutions Use Case

Challenge: Deploy and manage a growing list of security tools, including encryption IPS, WAFs, firewalls, SIEM, DDoS and SSL.

Solution: **Inline Tool Chaining**, allows you to manage the availability of your inline and out-of-band tools

- Chaining allows you to pass traffic through multiple inline tools
- Independently monitor the health of each inline tool with bypass heartbeats
- Load balance to the other tools 1:1 or 1:N tools
- Additionally send traffic to out-of-band monitoring tools

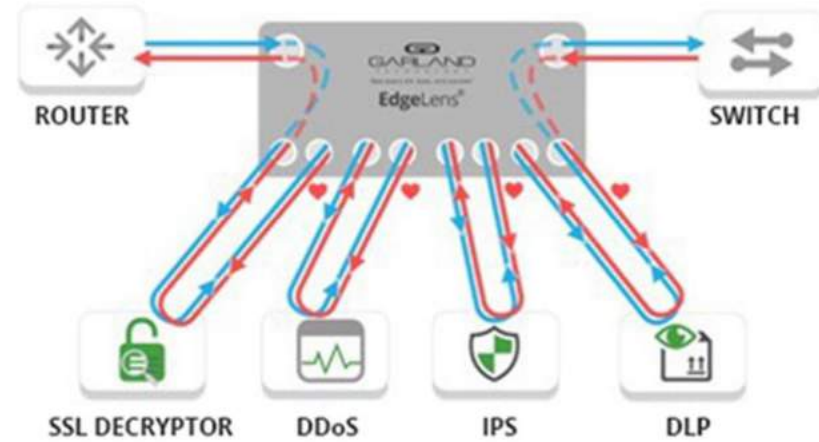

Managing Multiple Inline Tools

IT Security Solutions Use Case

Challenge: Deploy and manage a growing list of security tools, including encryption IPS, WAFs, firewalls, SIEM, DDoS and SSL.

Solution: **Inline Tool Chaining**, allows you to manage the availability of your inline and out-of-band tools

- Chaining allows you to pass traffic through multiple inline tools
- Independently monitor the health of each inline tool with bypass heartbeats
- Load balance to the other tools 1:1 or 1:N tools
- Additionally send traffic to out-of-band monitoring tools

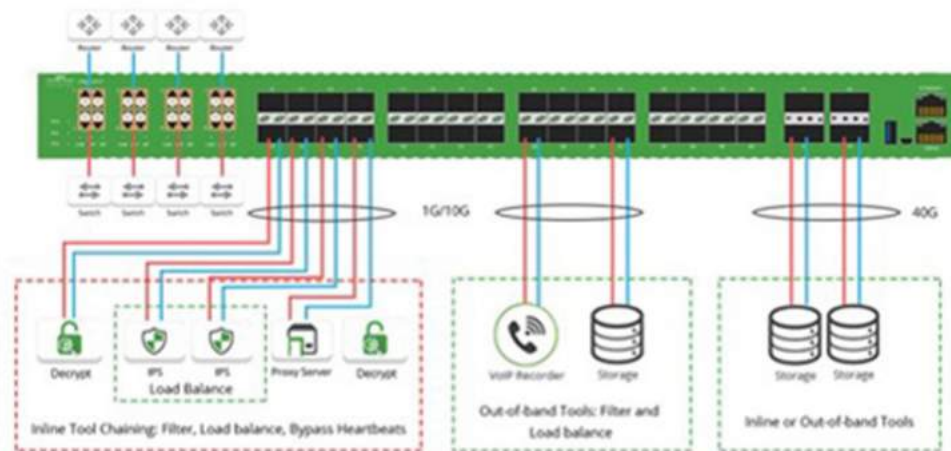

Optimizing Inline Tool Performance

IT Security Solutions Use Case

Challenge: Deploy and manage a growing list of security tools, including encryption IPS, WAFs, firewalls, SIEM, DDoS and SSL.

Solution: **Inline Tool Chaining**, allows you to manage the availability of your inline and out-of-band tools

- Chaining allows you to pass traffic through multiple inline tools
- Independently monitor the health of each inline tool with bypass heartbeats
- Load balance to the other tools 1:1 or 1:N tools
- Additionally send traffic to out-of-band monitoring tools

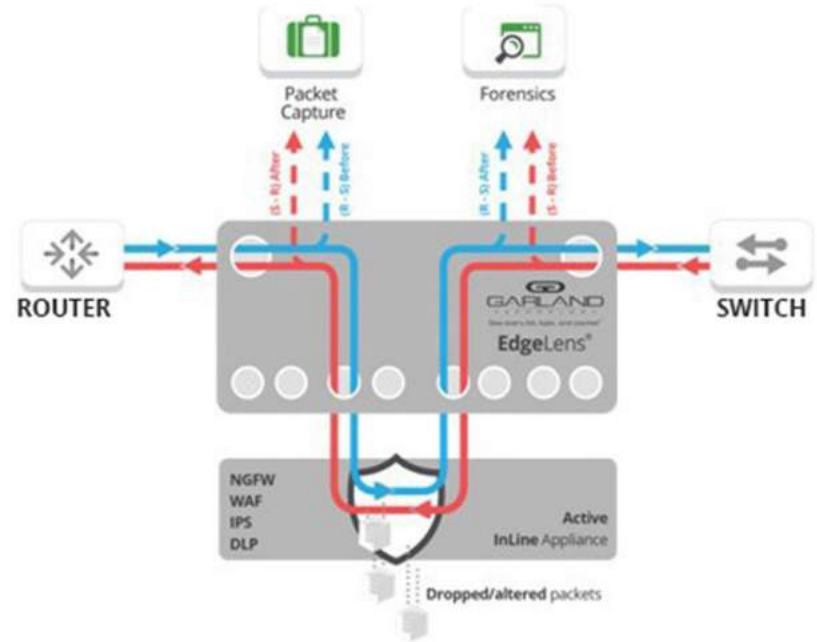

Adding Redundant HA Solutions

IT Security Solutions Use Case

Challenge: Erchitect an Intrusion Prevention Systems (IPS) for critical links with High Availability (HA) or redundant designs.

Solution: Garland offers two options for incorporating High Availability (HA) solutions into your network

- Active Standby (Active/Passive) deploys to a secondary tool, providing failover from primary device to backup appliance.
- The Active/Active Crossfire design incorporates a secondary tool and redundant link, providing the ultimate failover if either active device fails.

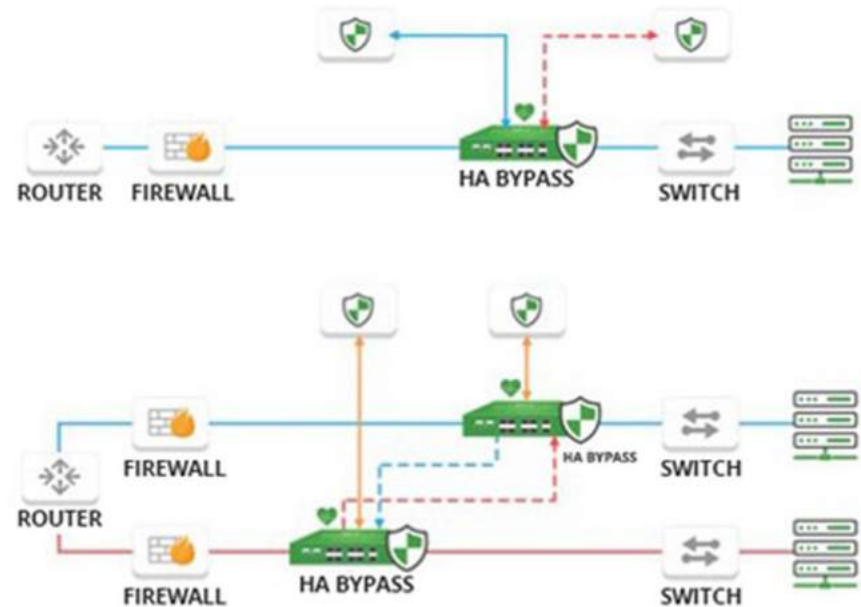

Inline Bypass TAPs







Providing Ultimate Reliability for Inline Edge Security

- Prevent inline tools from being single point of failure (SPOF)
- Tool Sandbox - Pilot or deploy new tools
- Manage multiple inline tools
- High Availability (HA) solution

Inline Bypass TAP Portfolio

Adding the resiliency modern networks need to be secure, from the inventor of bypass







EdgeSafe™ Bypass TAPs	EdgeSafe™ 1G Bypass Modular TAPs	EdgeSafe™ Integrated Bypass TAPs	EdgeSafe™ Bypass TAPs	EdgeSafe™ 40G / 100G Bypass Modular TAPs
				
100/1000M (1G)	100/1000M (1G)	100/1000M (1G)	1G/10G	40G/10G/100G
<ul style="list-style-type: none"> • Copper RJ45 [nm] • Single mode[ve] • Multi mode [n] • SFP [m] 	<ul style="list-style-type: none"> • Copper RJ45 [nm] • Single mode[ve] • Multi mode [n] • SFP [m] 	<ul style="list-style-type: none"> • Copper RJ45 [nm] • Single mode[ve] • Multi mode [n] 	<ul style="list-style-type: none"> • Single mode[ve] • Multi mode [n] • SFP [m] 	<ul style="list-style-type: none"> • Single mode[ve] • Multi mode [n] • SFP / QSFP+ / QSFP28 [m]
Portable	1U or 2U Chassis	1U Chassis	Portable	1U Chassis
<ul style="list-style-type: none"> • Reduce downtime for Inline tols w/small from factor • Bypass Heartbeats/Failsafe • Media conversion • Link Failure Propagation (LFP) • Plug&Play /Remote mnngt 	<ul style="list-style-type: none"> • Reduce downtime for Inline tols w/small from factor • Bypass Heartbeats/Failsafe • Media conversion • Link Failure Propagation (LFP) • Plug&Play /Remote mnngt 	<ul style="list-style-type: none"> • Eliminate downtime with High Availability (HA) bypass • Bypass Heartbeats/Failsafe • 6 Monitoring ports • Media conversion • Link Failure Propagation (LFP) 	<ul style="list-style-type: none"> • Reduce downtime for Inline tols w/small from factor • Bypass Heartbeats/Failsafe • Link Failure Propagation (LFP) • Plug&Play /Remote mnngt 	<ul style="list-style-type: none"> • Reduce downtime for Inline tols w/small from factor • Bypass Heartbeats/Failsafe • 6x 10G;3x40G TAPs or (2x) 100G TAPs • Media conversion • Link Failure Propagation (LFP) • Plug&Play /Remote mnngt

Inline Hybrid Packet Broker Portfolio

Simplify your security stack, from the inventor of bypass



EdgeLens® Focus Inline Security Packet Broker	EdgeLens® Inline Security Packet Broker	EdgeLens® Inline Security Packet Broker	EdgeLens® Inline Security Packet Broker
			
<p style="text-align: center;">1G/10G</p>	<p style="text-align: center;">1G/10G</p>	<p style="text-align: center;">40G</p>	<p style="text-align: center;">100G (Q122)</p>
<p>Single Mode [nJ] Multi Mode [n] SFP+ [m]</p>	<p>Single Mode [nJ] Multi Mode [n] •SFP+[m] Tools: : 40G/10G/1G</p>	<p>SR4 [n] • LR4 [n] • SFP+ / QSFP+ [m] • Tools: 40G/10G/1G</p>	<p>SR4 [n] LR4 [nJ] QSFP+ / QSFP28 [m] Tools: 100G/40G/25G/10G</p>
<p>• ½ Rack 1U Chassis</p>	<p>• High Density 1U Chassis</p>	<p>• High Density 1U Chassis</p>	<p>• High Density 1U Chassis</p>
<ul style="list-style-type: none"> • Manage multiple inline and out-of-band tools in half rack • Bypass Heartbeats/Failsafe • High Availability (HA) • Filtering, Aggregation and Load Balancing • Hardware base chaining • Remote mnngt 	<ul style="list-style-type: none"> • Manage multiple inline and out-of-band tools in 1U • Bypass Heartbeats/Failsafe • High Availability (HA) • Filtering, Aggregation and Load Balancing • Hardware base chaining • Remote mnngt 	<ul style="list-style-type: none"> • Manage multiple inline and out-of-band tools in 1U • Bypass Heartbeats/Failsafe • High Availability (HA) • Filtering, Aggregation and Load Balancing • Hardware base chaining • Remote mnngt 	<ul style="list-style-type: none"> • Manage multiple inline and out-of-band tools in 1U • Bypass Heartbeats/Failsafe • High Availability (HA) • Filtering, Aggregation and Load Balancing • Hardware base chaining • Remote mnngt

Solutions that work

Access and Visibility

ICS Visibility Architecture

ICS Security Solution Provide:



- Real-time Threat Detection
- Asset discovery and management of devices and firmwares
- Ensure Compliance Standards
- Operational visibility and risk reduction

Security Solutions Need Visibility

You Cannot Secure, What You Cannot See

- Security solutions are only as good as the data they analyze.
- Blindspots hide threats and anomalies

ICS Visibility Challenges

Within OT Environments

- Relying on **legacy switch SPAN ports** for visibility, that aren't secure, reliable or available
- Face different **media or speed** connections
- Network sprawl with a need to **reduce network complexity** and optimize traffic
- Require **unidirectional** connectivity
- Need an **air gapped** solution for virtual environments



Garland Technology Solves These Challenges

- Providing ICS Security tools 100% packet visibility
- Accommodate media and speed conversion
- Streamline network complexity through traffic aggregation
- Ensuring unidirectional connectivity with Data Diode TAPs
- Air-gap virtual traffic mirroring vTAP



Provide ICS Security Tools 100% Packet Visibility

Eliminate Blind Spots and Improve Tool Performance

Network TAPs

- 100% Full duplex copy of network traffic
- Scalable and can either provide a single copy, multiple copies (regeneration), or consolidate traffic (aggregation) to maximize the production of your monitoring tools.
- Does not affect the network / Passive or failsafe
- Rugged and reliable, DIN rail, DC power converters
- Easy, plug and play

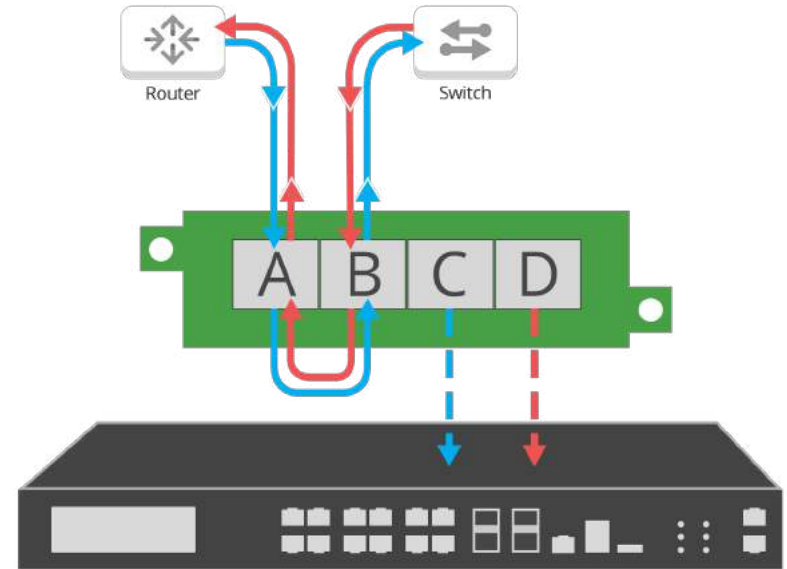

SCADAfence & Garland

Continuous Monitoring for Industrial Environments

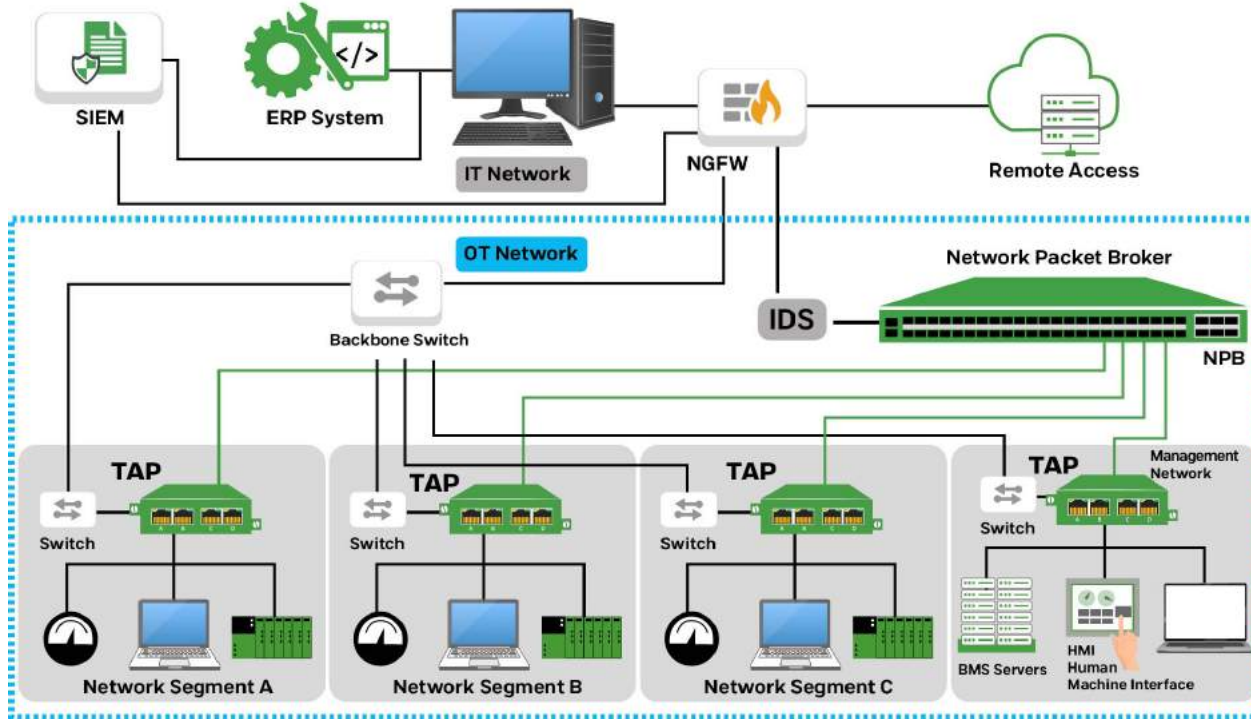

OT Environment Use Case

Utilities: Power, Water, and Wastewater Redundant Network Visibility Fabric

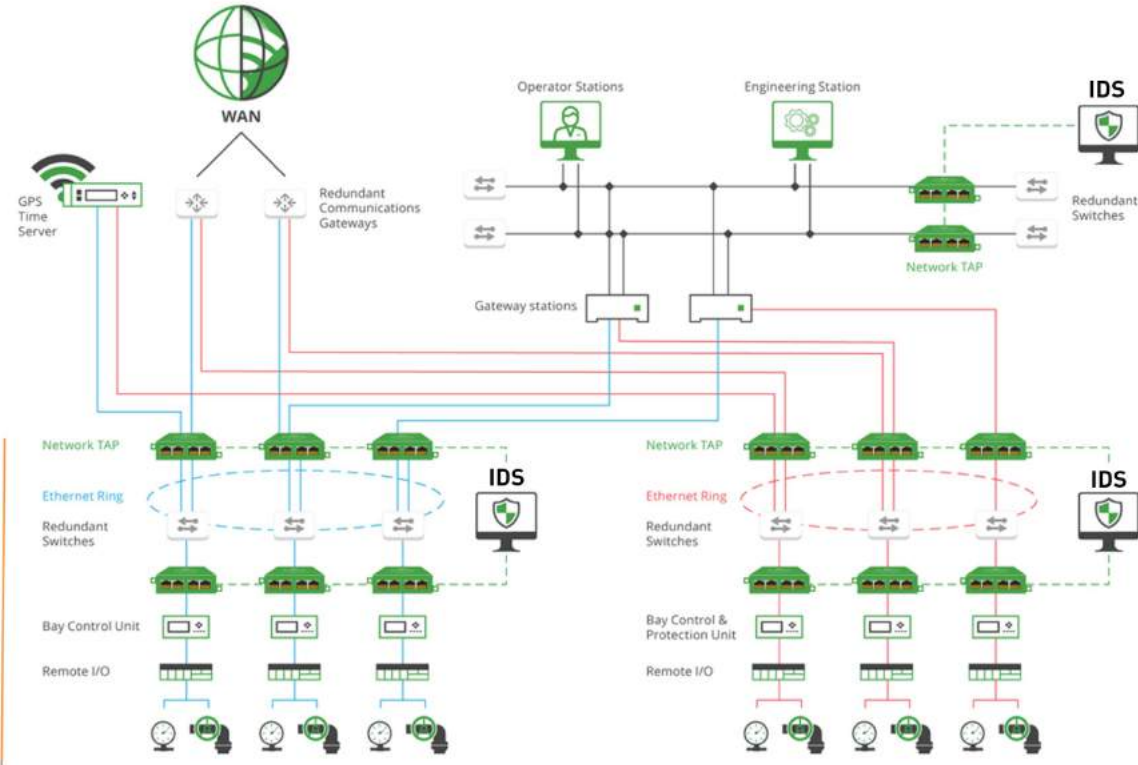

OT Environment Use Case

Utilities: Power, Water, and Wastewater Visibility Fabric

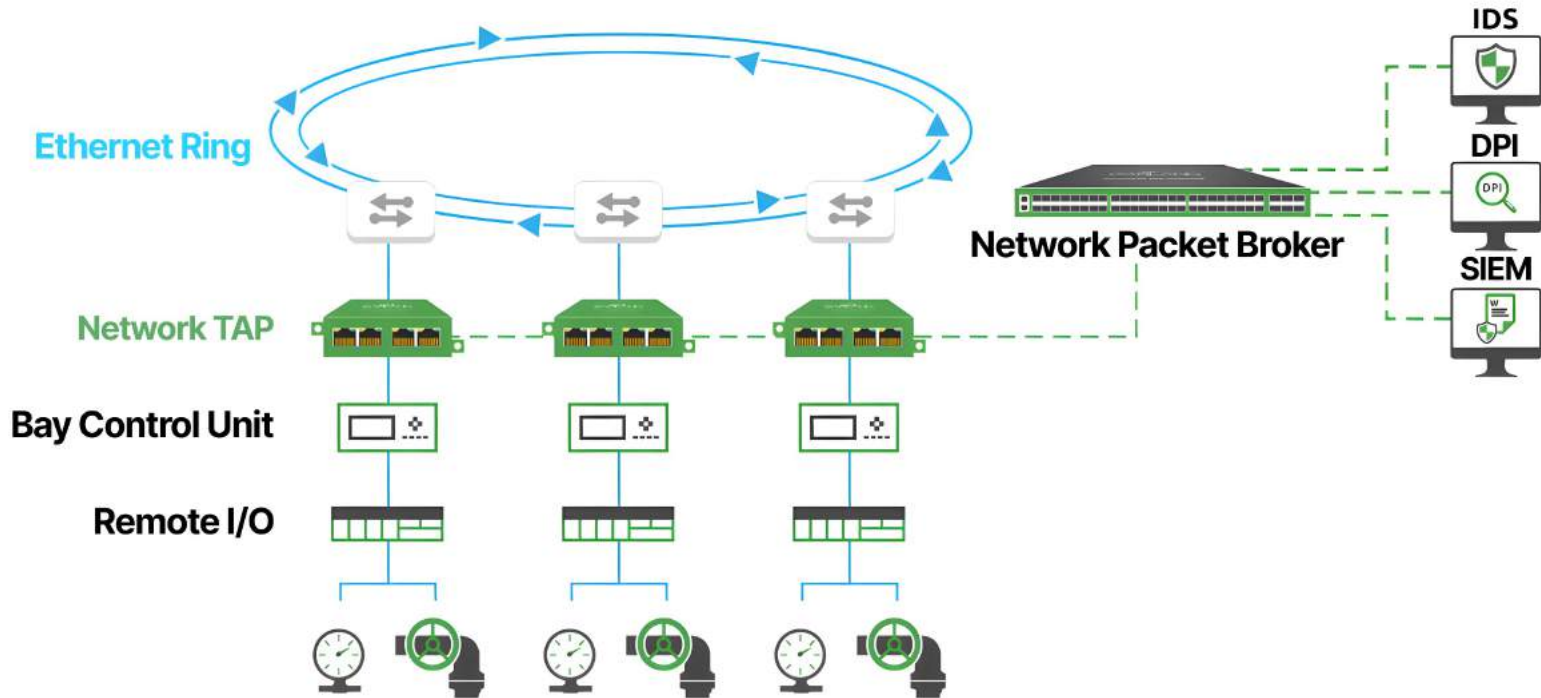

OT Environment Use Case

Oil & Gas Purdue Model Visibility Fabric

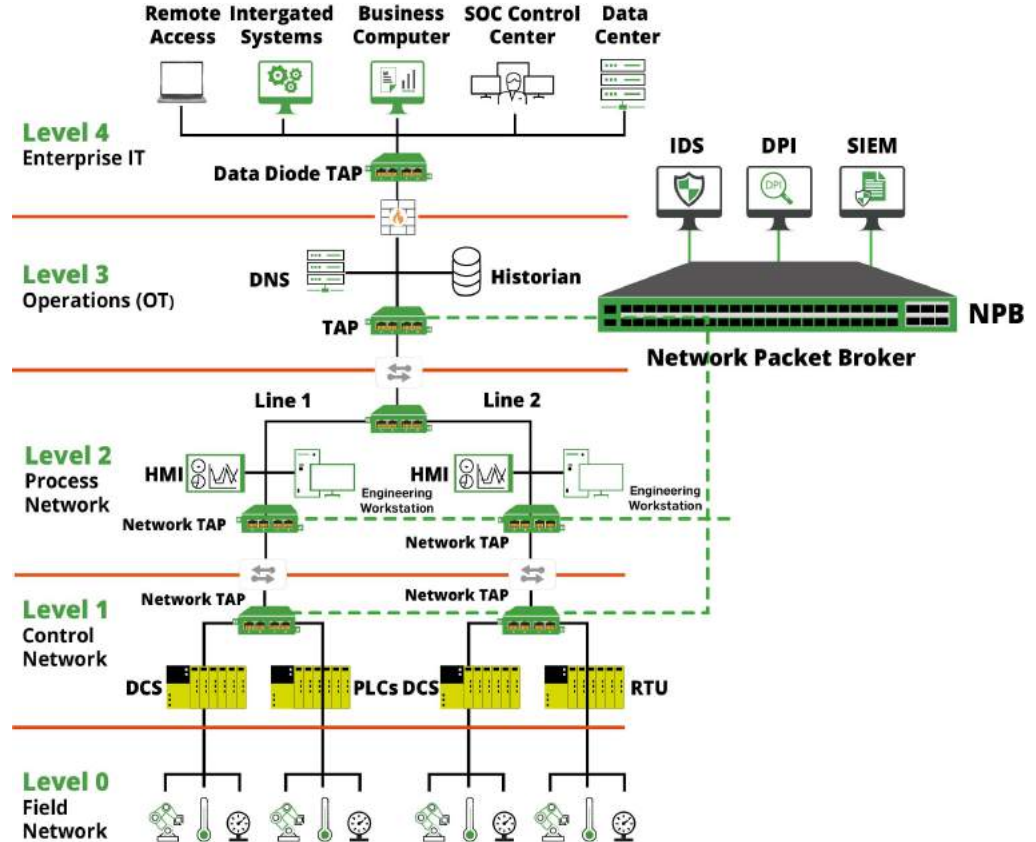

OT Environment Use Case

Oil & Gas Visibility Fabric

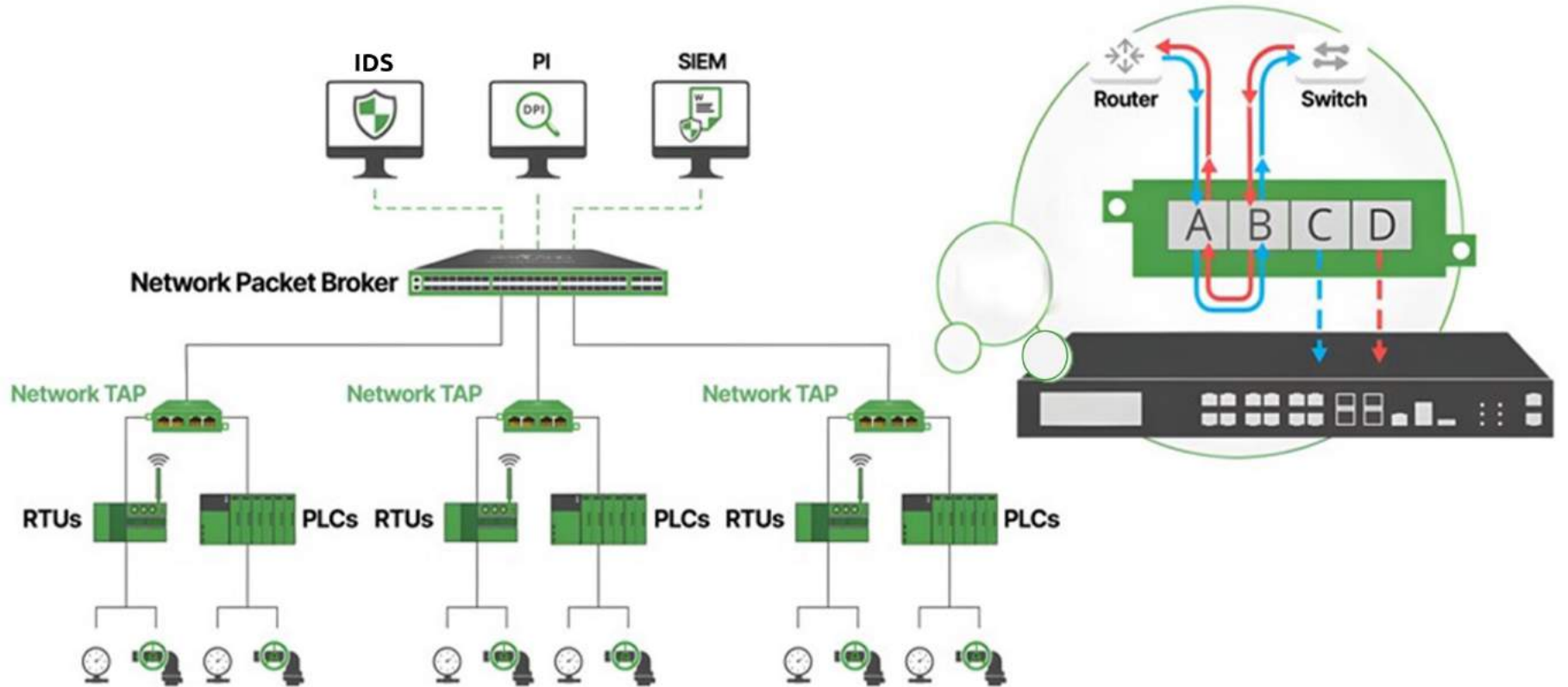

OT Environment Use Case

Manufacturing and Pharmaceuticals Visibility Fabric

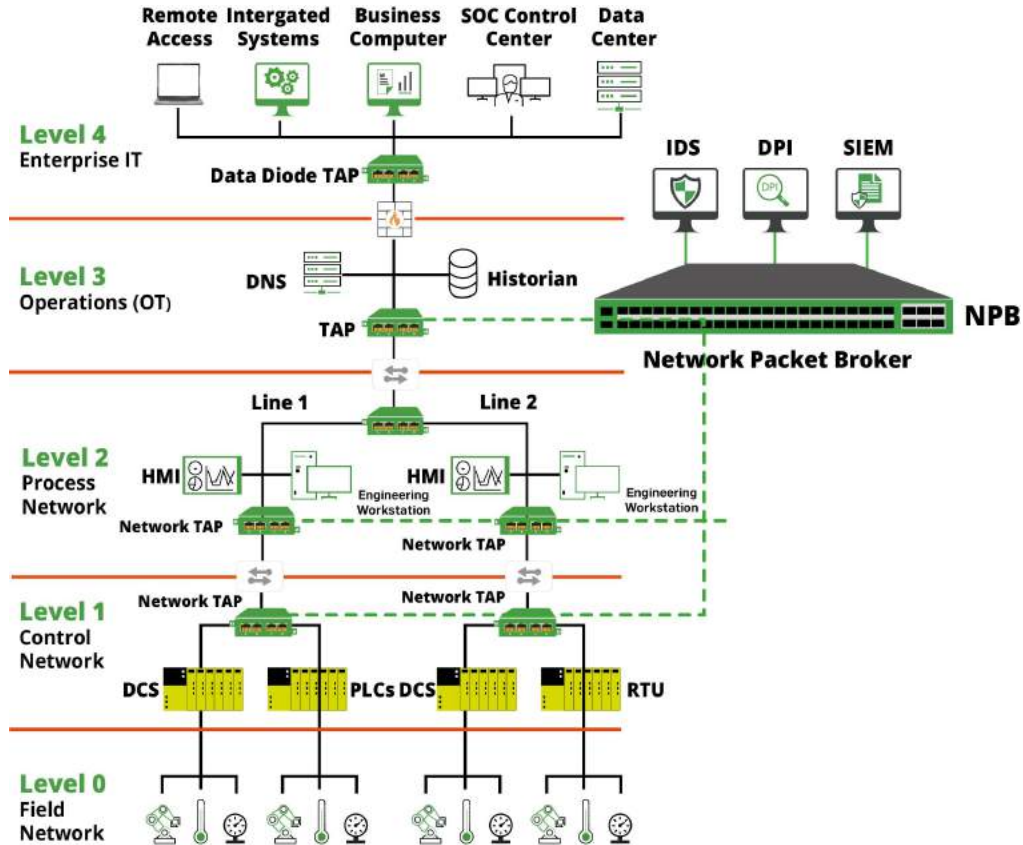

OT Environment Use Case

Manufacturing and Pharmaceuticals Visibility Fabric

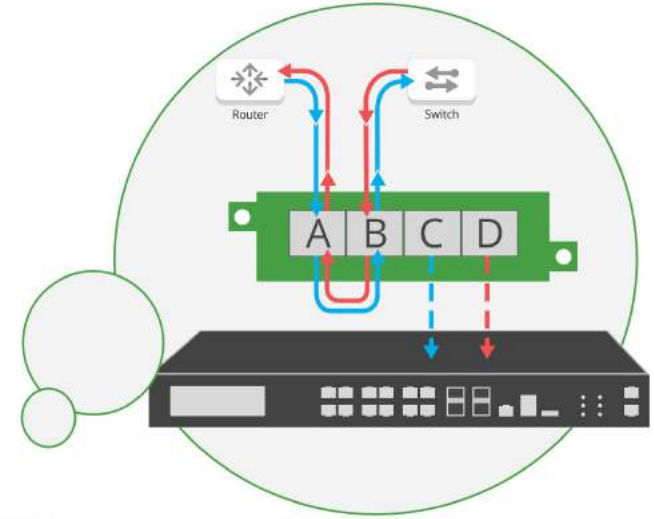
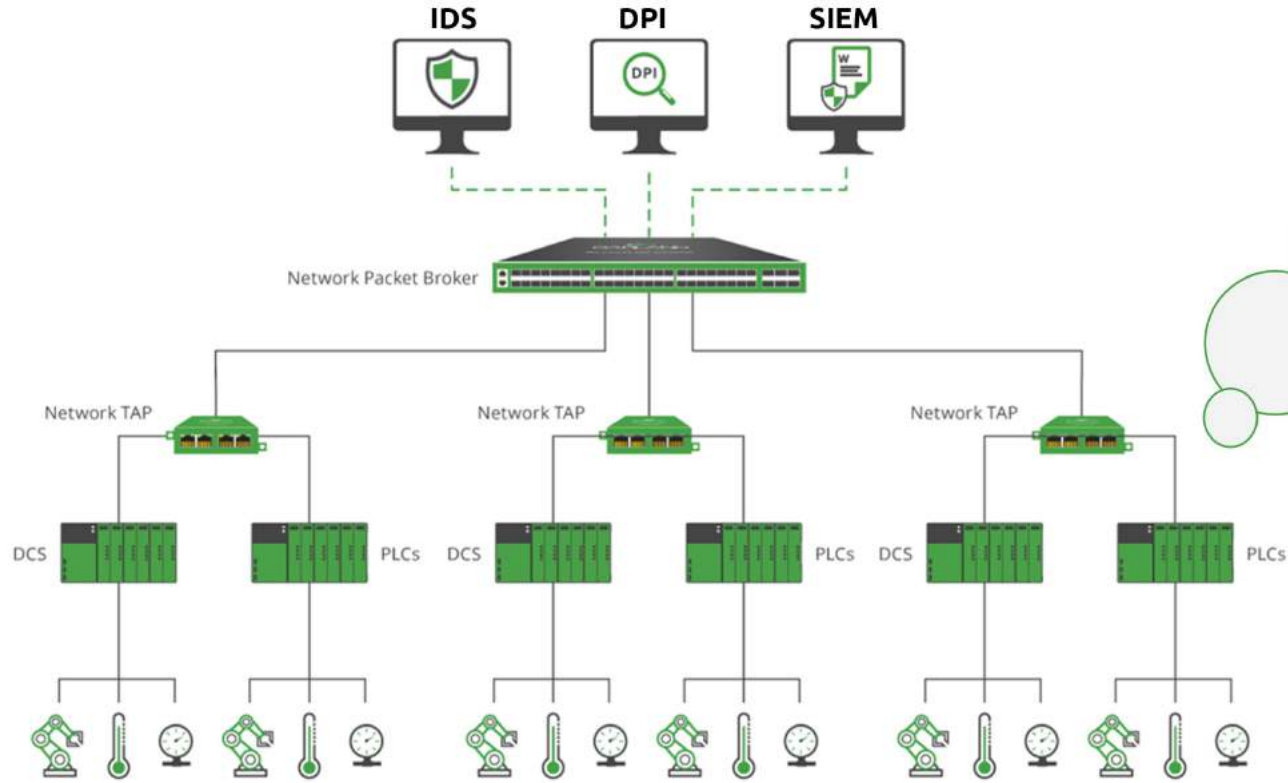

OT Environment Use Case

Substation SCADA Virtualization and Firewall Optimization

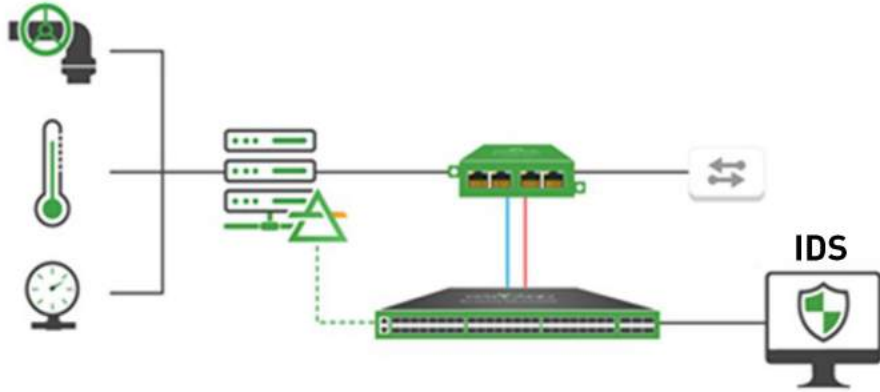

- Captures Virtual SCADA packets
- TAP physical interface data
- Aggregates both physical and virtual data
- Transports Substation data to main data centers
- Full substation data visibility

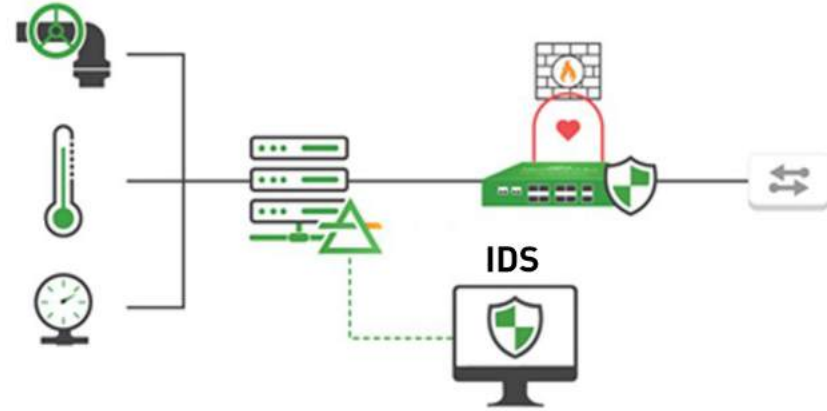

- SW updates to firewalls causes network downtime
- Loss of substation data visibility
- Bypass TAP maintains network availability
- Improved visibility during security updates

Implementing Out-of-Band Visibility Architecture

CASE STUDIES

Health Inline Bypass TAP's

Gaining Full Visibility During an Instant Response Data Breach

Cyber Defense Group, a healthcare group's incident response team stopped a data breach with Garland.

Solution: Network TAPs provided 100% visibility

Garland allowed CDG to quickly gain visibility to the proprietary tools they use for full packet capture in the cloud, intrusion detection (IDS), enterprise security monitoring, NGFW and log management to properly resolve the data breach.

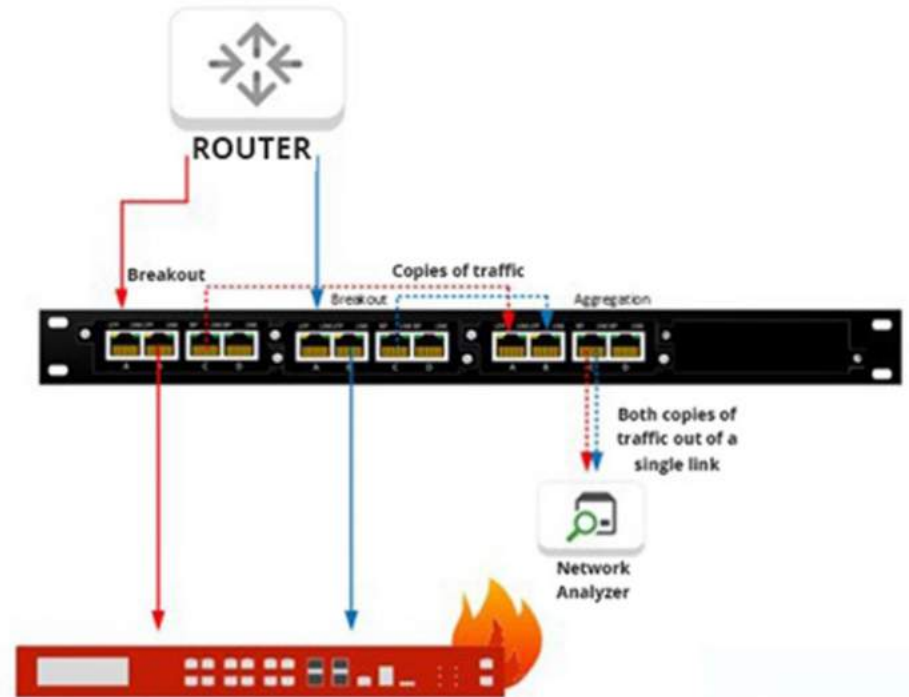

Monitoring 5G Environments

Troubleshooting User performance Issues at the Fronthaul

A mobil wireless provider launching a national 5G network gained full packet-level visibility for thorough testing and monitoring at elevated speeds.

Solution: Garland's 25G Passive Fiber Network TAPs feeding SYNESIS 25G Portable, provided packet capture visibility at the moment's notice

- Replaced existing 10G TAPs, that couldn't accommodate 25G
- Eliminated need for large space and power requirements versus rackmount systems
- Complete «zero packet loss» visibility provided confidence in analysis results
- Lowered CapEx cost for portable high-density equipment
- Lowered OpEx cost for onsite personnel

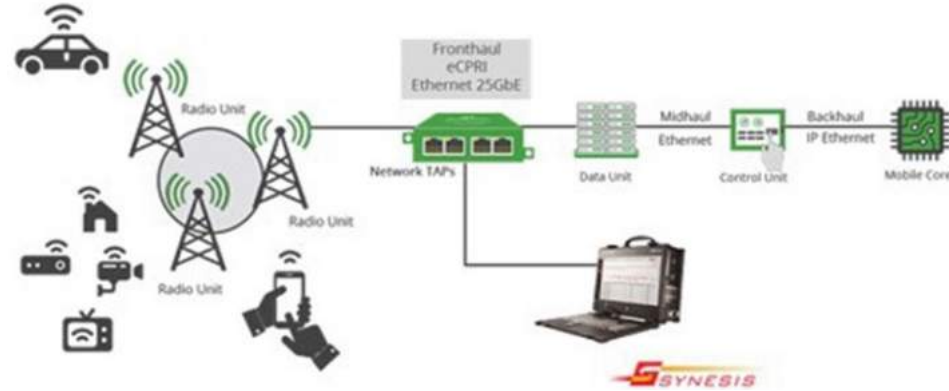

Monitoring Telecommunications

Improve Visibility to Enhance Remediation and Resolve Vulnerability

Prepaid Wirelss Group added Garland visibility to improve network remediation and resolve network vulnerability

Solution: Deployed Garland's 40G passive fiber SelectTAP ve PacketMAX feeding Cirries' PacketPoint, packet capture appliances.

- Streamlined data collection workflows for analysis during
- Improved visibility provided network troubleshooting and resolution
- Reduced complexity and improve network performance
- Lowered OpEx cost for onsite personnel

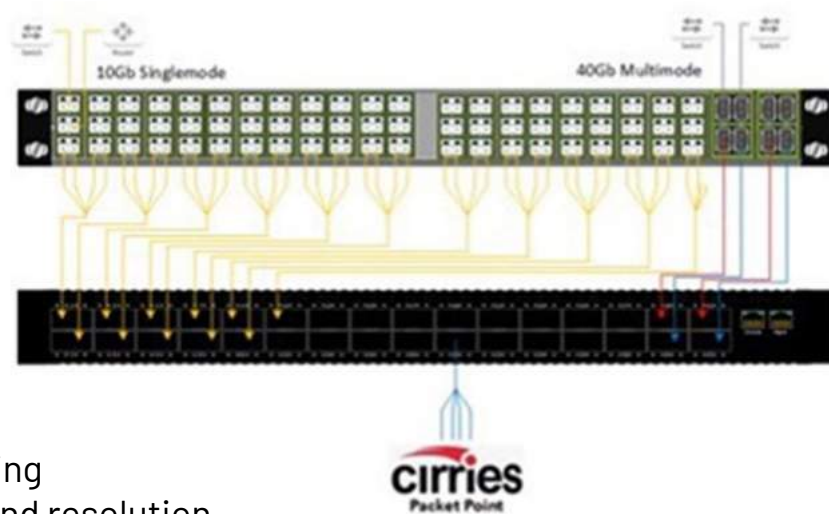

Industrial Infrastructure

Providing Visibility and Reducing Network Complexity

A leading O&G company looking to reduce connectivity complexity, enable higher performance—helping to bridge the OT and IT

Solution: A combination of Aggregator TAPs and PacketMAX packet brokers deployed throughout the network, feeding back to a central location.

- Reduce complexity and administrative overhead
- Enable infrastructure upgrades
- Improved the network performance
- Improve effectiveness of tool performance

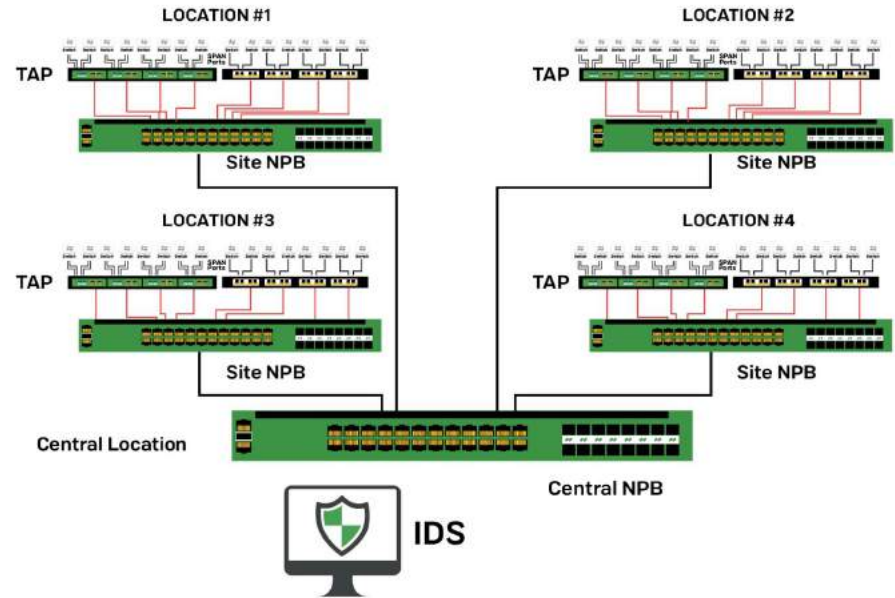

Federal Full Packet Capture

Custom Solutions for Mission Critical Data

The Department of Defense turns to garland for custom, durable, high-quality, fast turnaround.

Solution: Custom TAPs for Extreme Environments

Garland, developed custom-built TAPs o withstand environmental and durability concerns, to feed operational data to a packet capture tool and onto hard drives, ensuring 100% complete mission critical data was collected.

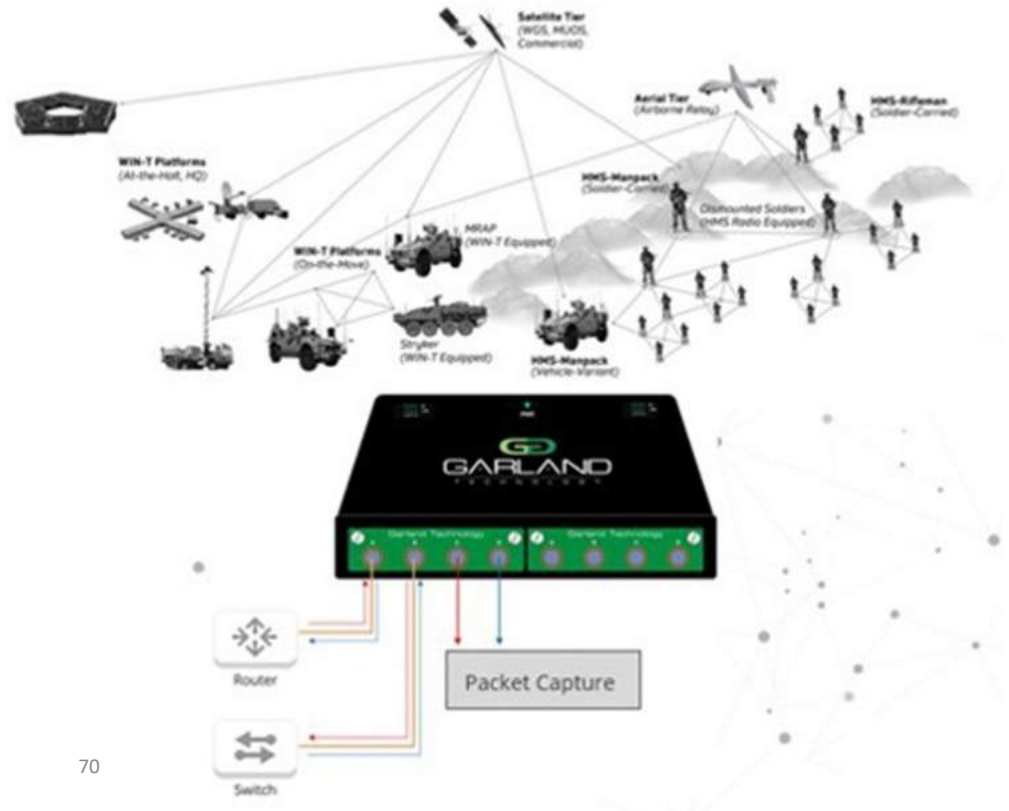

IT Visibility Architecture

Security/Monitoring Fabric

Providing Visibility to Ensure Performance & Security

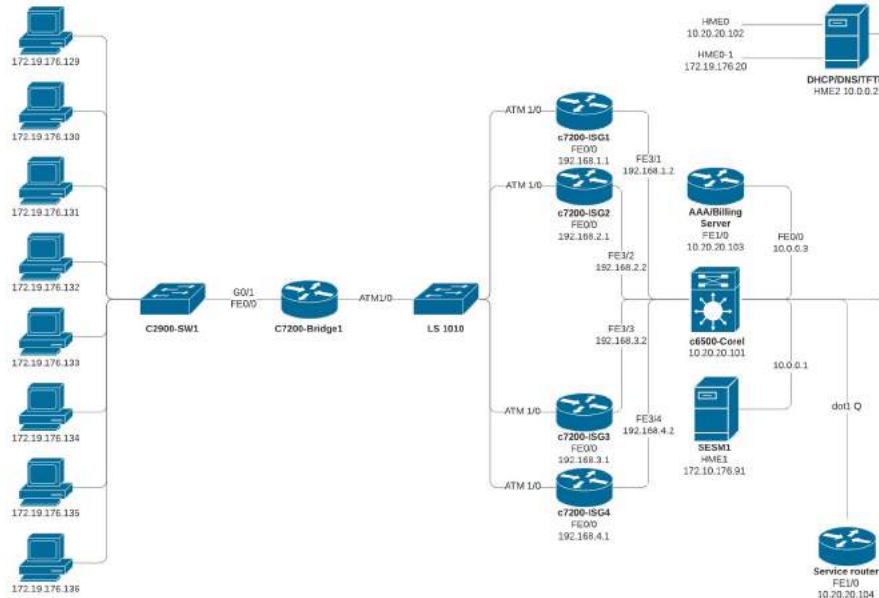

Security/Monitoring Fabric

Providing Visibility to Ensure Performance & Security

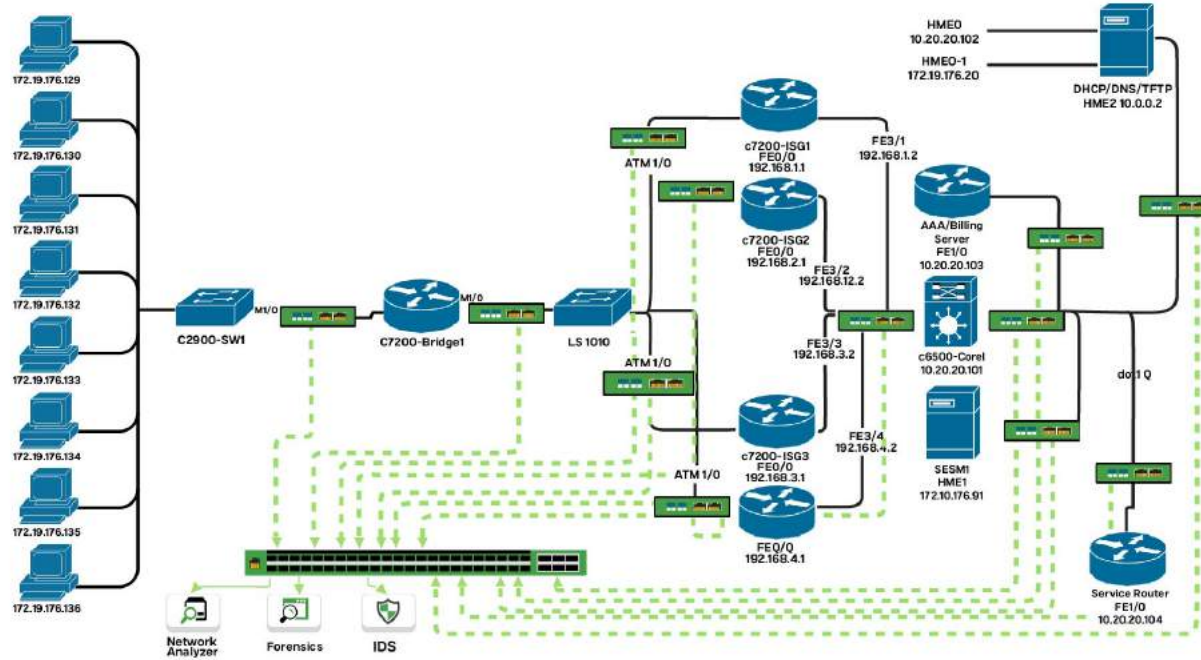

Use Case: TAP 8 links in different locations and aggregate down to one monitoring port.

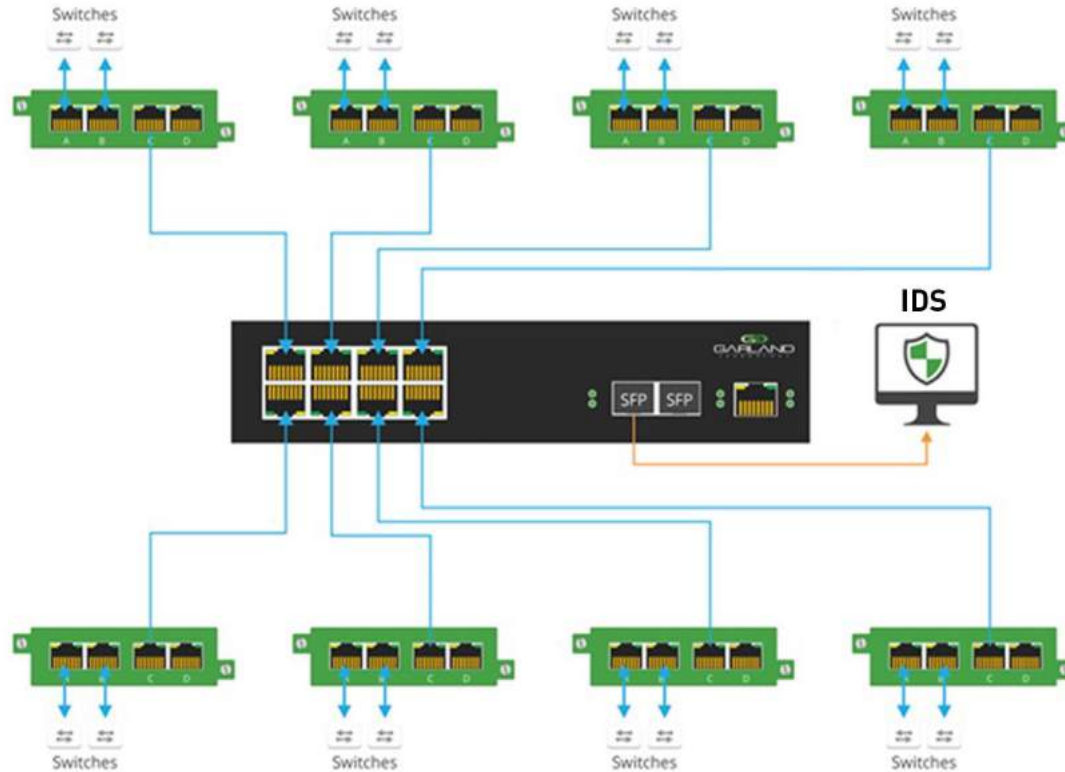

Medium Sites

TAP + Aggregation 1-100G Monitoring

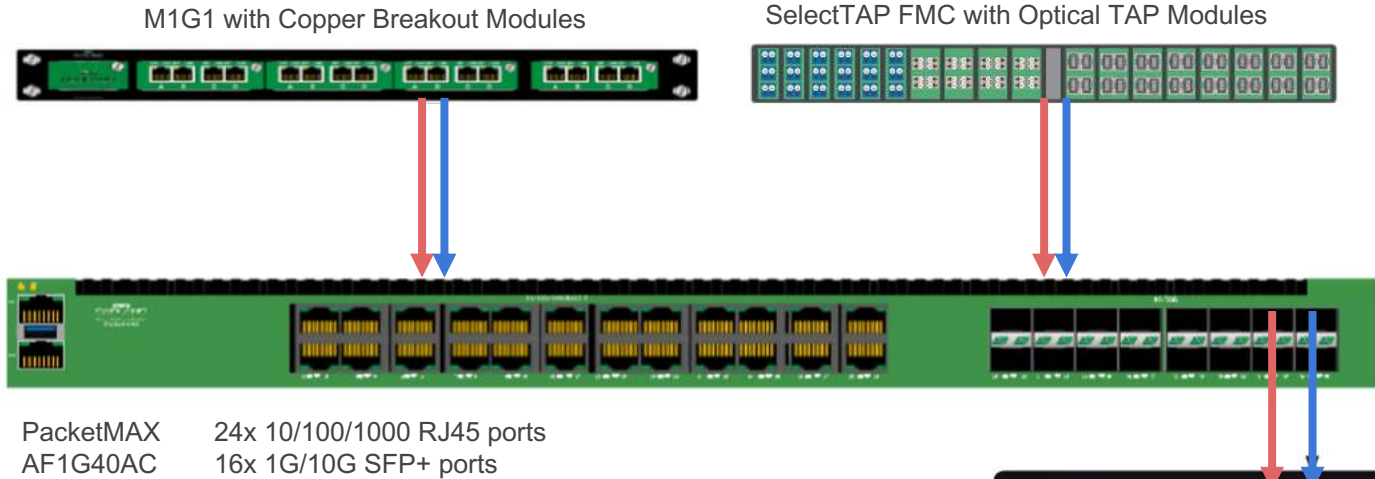

TAP many links

- 1/10/25/40/100G Fiber TAP
- 10/100/1000M Copper TAP

Benefits

- Aggregate many links
- Advanced features
- Minimal Tool ports
- Reduce complexity



Large Sites

TAP + Aggregation 1-100G Monitoring

10G links

- Aggregate many TAP links
- Aggregate many SPAN links

Benefits

- 100% wire data visibility
- Advanced aggregation and load balancing
- Deduplication
- Load balance 25G links to Tool
- Media Conversion

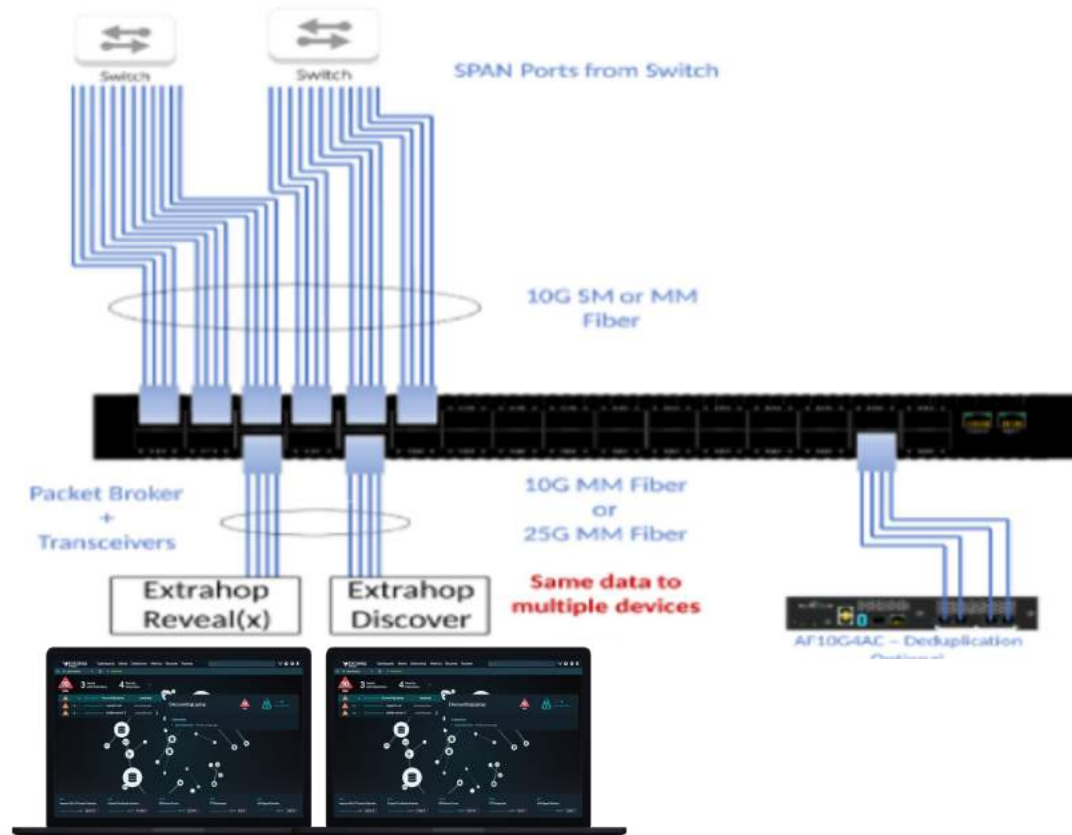

Multi-location Intrusion Detection Solution

Providing Visibility and Reducing Network Complexity

An example solution with a single IDS monitoring multiple locations

Solution: A combination of Network TAPs and PacketMAX packet brokers deployed throughout the network, feeding back to a central location.

- Reduce costs, complexity and administrative overhead
- Enable infrastructure upgrades
- Improve effectiveness of tool performance

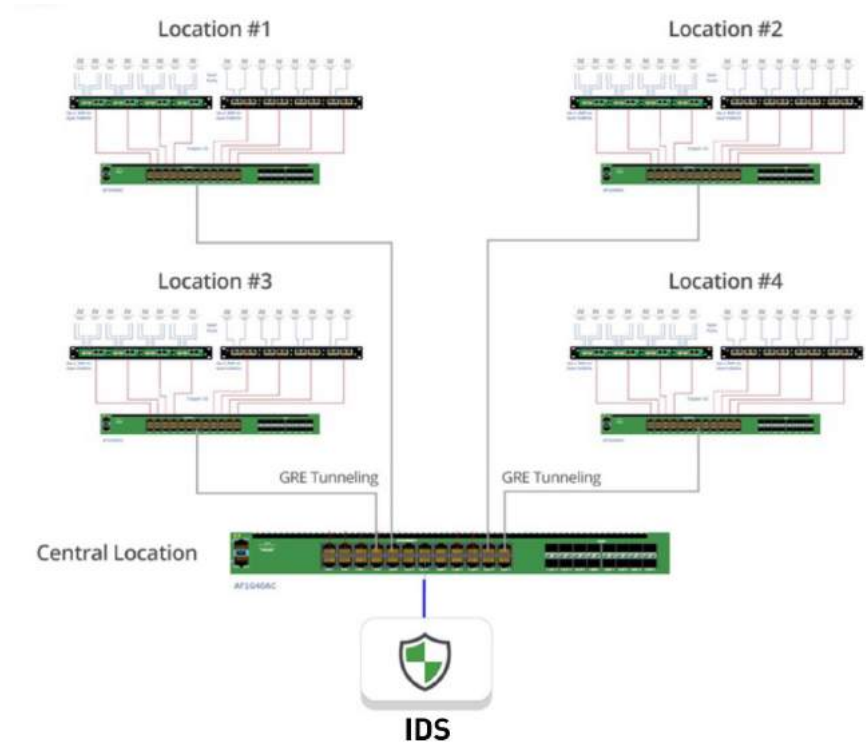

Use Case: TAP and SPAN many links in various locations and GRE Tunnel back to a central location.

TAP LINKS – Entering between the Industrial Device and the switch it is connected to

SPAN Port or post-monitoring from switches in industrial environment

TAP LINKS – Entering between the Industrial Device and the switch it is connected to

SPAN Port or post-monitoring from switches in industrial environment

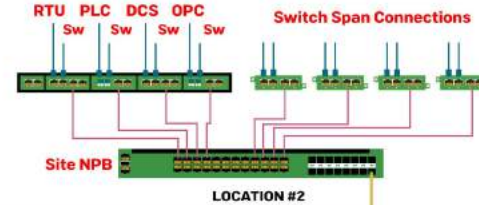
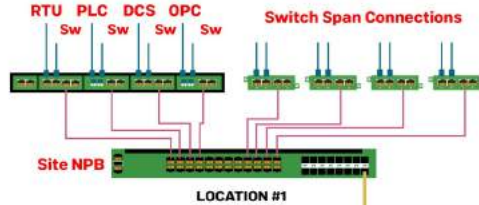

TAP LINKS – Entering between the Industrial Device and the switch it is connected to

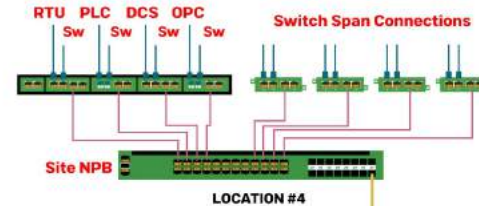
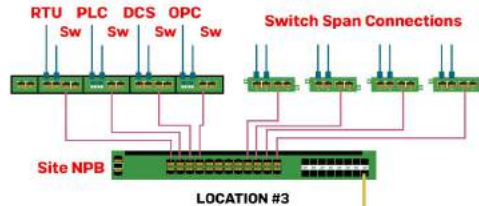

Center Network Packet Broker

Infrastructure Protection

Providing Added Visibility for Airgapped Unidirectional Pathways

Secure out-of-band analysis

Solution: Data Diode TAPs:

- Disallows bidirectional traffic to protect against back flow of traffic into the network
- Secure – TAPs do not have a IP address, or MAC address and cannot be hacked.
- Protects additional source of data streams like switch SPAN ports and network links
- Network traffic control is enforced at the physical level

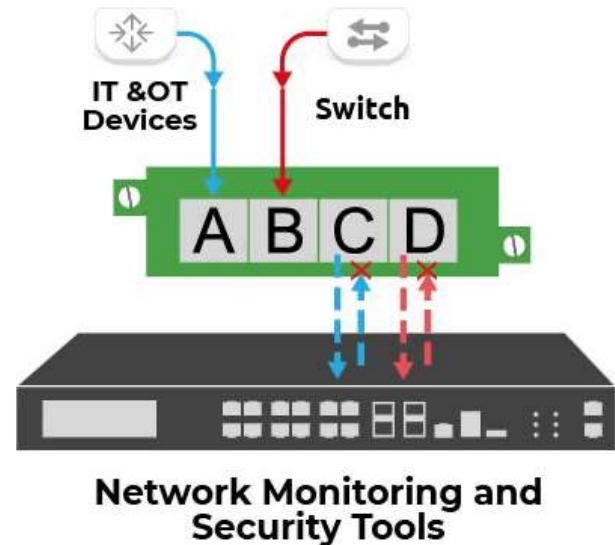

Connecting Inline Security Devices

IT Security Solutions Use Case

Challenge: Managing the risk of downtime is a critical consideration when deploying security tools.

- Device failures can bring down the network
- Deploying new technologies into the network
- Scheduling off hour planned downtime

Solution: Bypass TAP “inline lifecycle management”

- Easily take tools out-of-band for updates, installing patches, maintenance, or troubleshooting
- Simplify tool piloting and deployment
- Administrative isolation
 - No maintenance windows
 - Reduced network impact and downtime

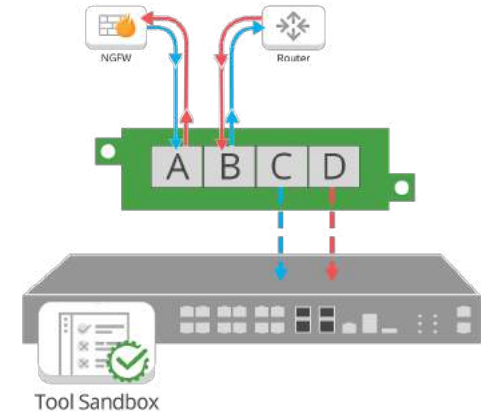
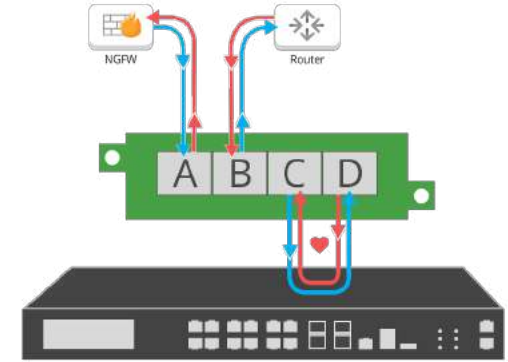

Optimizing Inline Tool Performance

IT Security Solutions Use Case

Challenge: How to troubleshoot inline tools (IPS, firewalls etc) are configured and optimized properly.

Solution: *Before and After Optimization & Validation* allows you to provide visibility to out-of-band packet capture, storage and analysis tools

- Analyze packet data before and after your inline device to ensure optimal tool performance to validate any updates or troubleshoot why threats weren't blocked
- Enable real-time proof-of-concept evaluations without impacting the network
- Validate tool changes or updates are configured properly

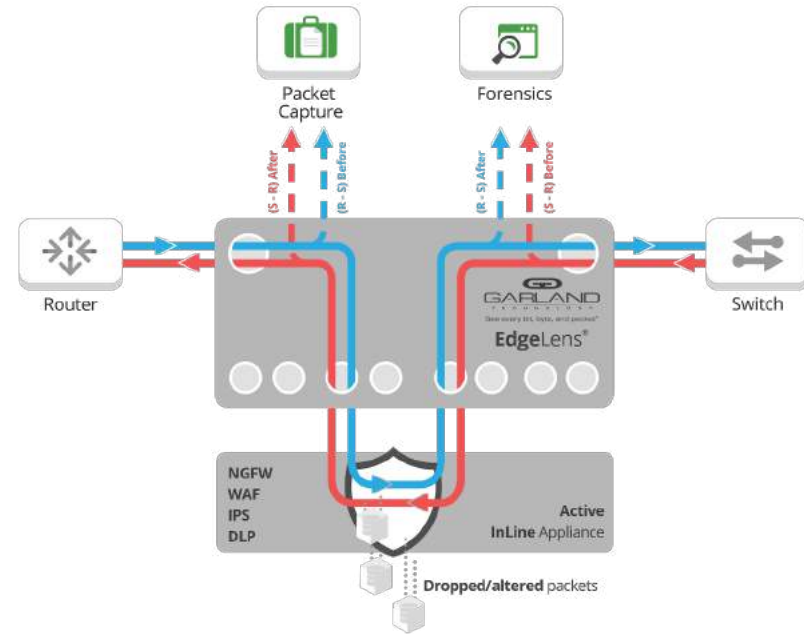

The image features a world map in shades of blue and teal, centered on a background of binary code (0s and 1s) in a light gray color. A large, metallic padlock is superimposed over the map, with its shackle at the top and the body of the lock covering the central and lower portions of the globe. The text "Out-of-band Customer Solutions" is written in a bold, dark blue font across the lower part of the padlock.

Out-of-band Customer Solutions

OT Environment

+ Situation

+ Large manufacturing customer with no security in OT Environment

+ Requirement

+ Implement an IDS solution

+ Solution

+ Portable copper TAP<2s with DIN Rail mounting

+ High Density Aggregation TAP

+ Network Packet Broker

+ Benefit

+ Secure Access to data

+ Data Diode Taps

+ Reduced implementation cost equipment required

+ Highest level of security

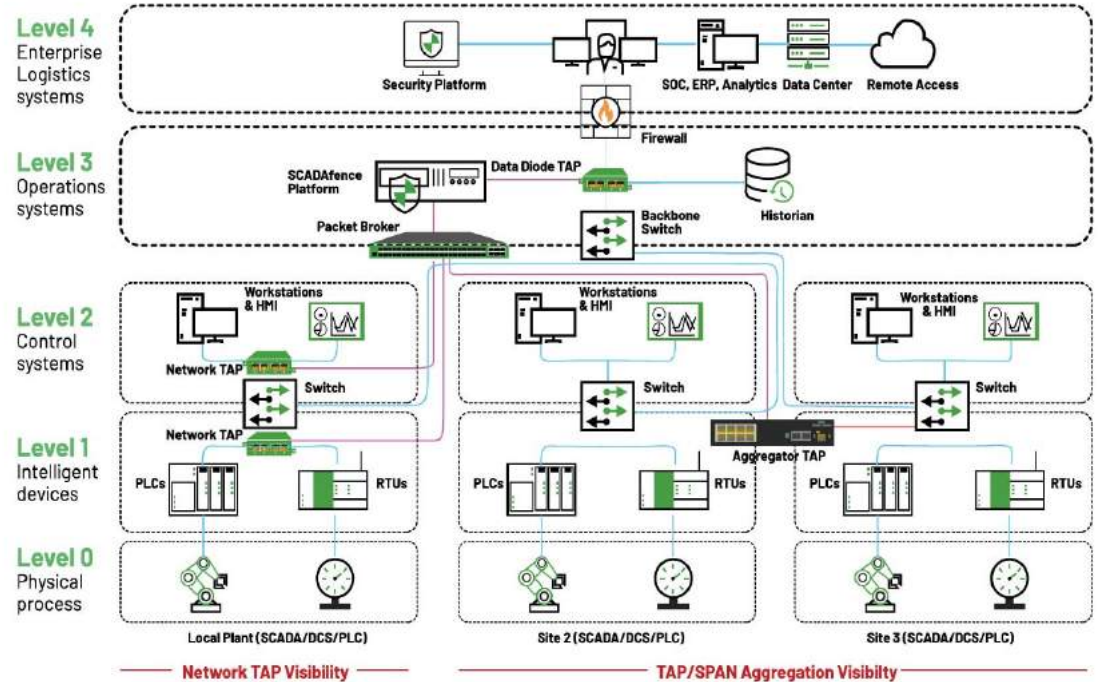

OT Environment

+ Situation

+ Large utility with no security in OT Environment

+ Requirement

+ Implement an IDS solution

+ Solution

+ High Density SPAN Aggregation TAP (Data Diode)

+ Network Packet Broker

+ Benefit

+ Increased security

+ SPAN ports protected with Data Diode TAP's

+ Reduced cost

+ Smaller IDS platform required

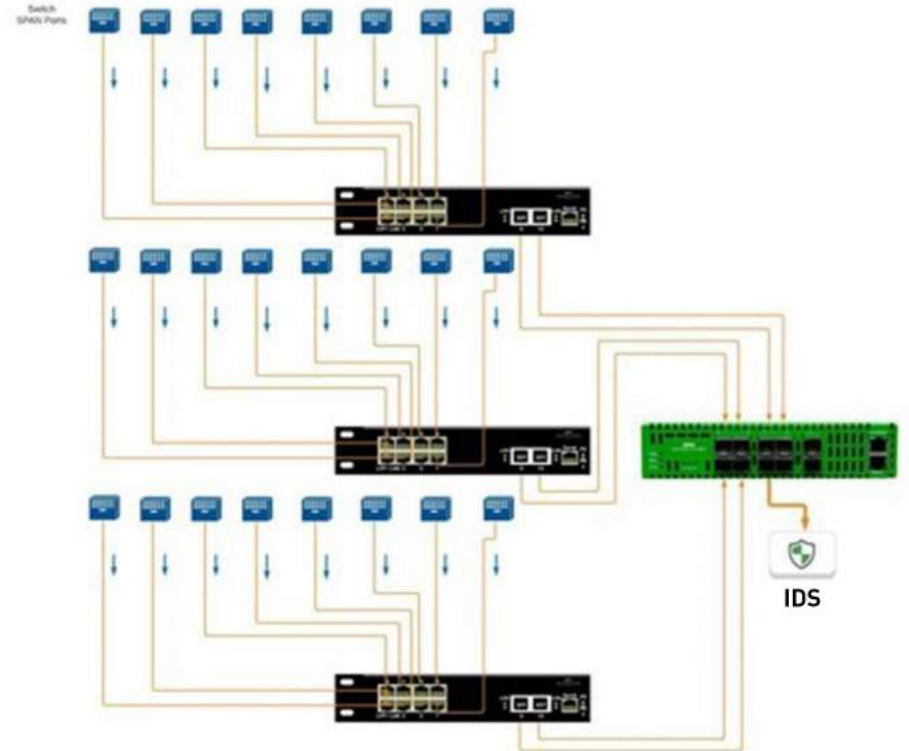

OT Environment

+ Situation

+ Large Energy provider with no security in OT Environment

+ Requirement

+ Implement an IDS solution

+ No blind spots

+ Satisfy regulatory requirements

+ Solution

+ Data Diode Network TAP's

+ Data Diode Virtual TAP's

+ Network Packet Brokers

+ Benefit

+ Increased security

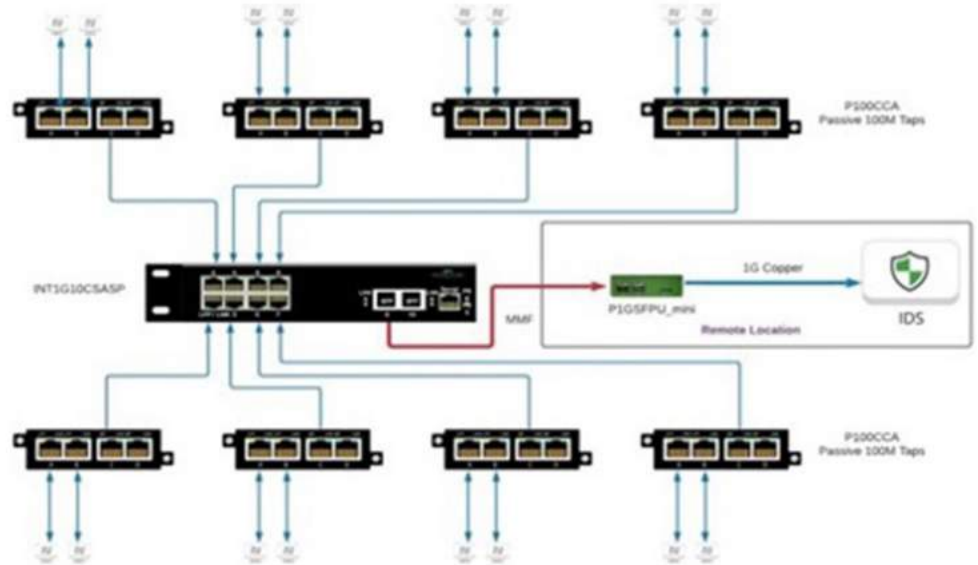

OT Environment

+ Situation

+ Large Energy provider with no security in OT Environment

+ Requirement

+ Implement an IDS solution

+ No blind spots

+ Satisfy regulatory requirements

+ Solution

+ Data Diode Network TAP's

+ Data Diode Virtual TAP's

+ Network Packet Brokers

+ Benefit

+ Increased security

Substation - SCADA Virtualization

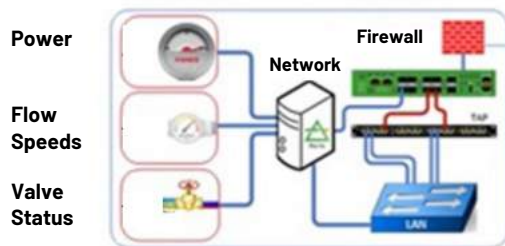

Substation - Refresh Optimization

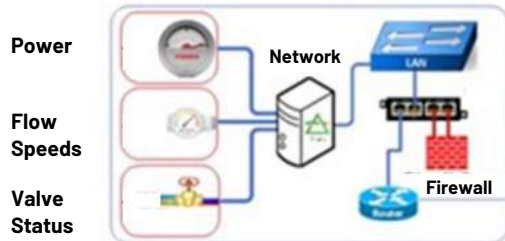

For your virtualized SCADA network deployments with 100% packet visibility SCADA Virtue Station Mon • Garland PRISM's • Garland TAPs • Garland Collector

Master Assistant Service Data Center

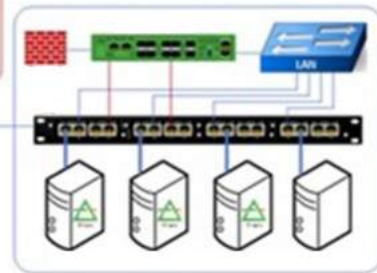

Private Cloud Private WAN

Firewall Optimization

Script remote upgrades of your substation firewall software, protecting the substation with security and visibility • Garland Bypass TAPs

Garland Auxiliary Service Visibility Utility Solutions Secure your substation communications network and infrastructure and main data center communications center from malicious security breaches. Garland offers a complete end-to-end visibility solution - including virtualized SCADA mon Spring, physical copper & fiber TAPs, and packet Collector providing 100% visibility into your utility infrastructure.

Enterprise Environment

+ Situation

+ Large Insurance Company

+ Requirement

- + Implement a multi location IDS solution
- + Cisco Meraki environment has limited SPAN ability
- + Wnted security monitoring between Access Stacks

+ Solution

- + Secure Passive Fibre TAPs
- + Network Packet Broker with integral fibre TAPs

+ Benefit

- + Increased security
- + Visibility between Core and Access Stacks
- + Guaranteed 100% packet visibility

+ Reduced cost

- + Smaller IDS platform required
- + NPB included TAP's

+ Reduced Space required

+ 2U Space on large sites, 1U on smallest sites

+ Operational cost saving

- + Consistent product family accross all locations
- + No SPAN port management overhead

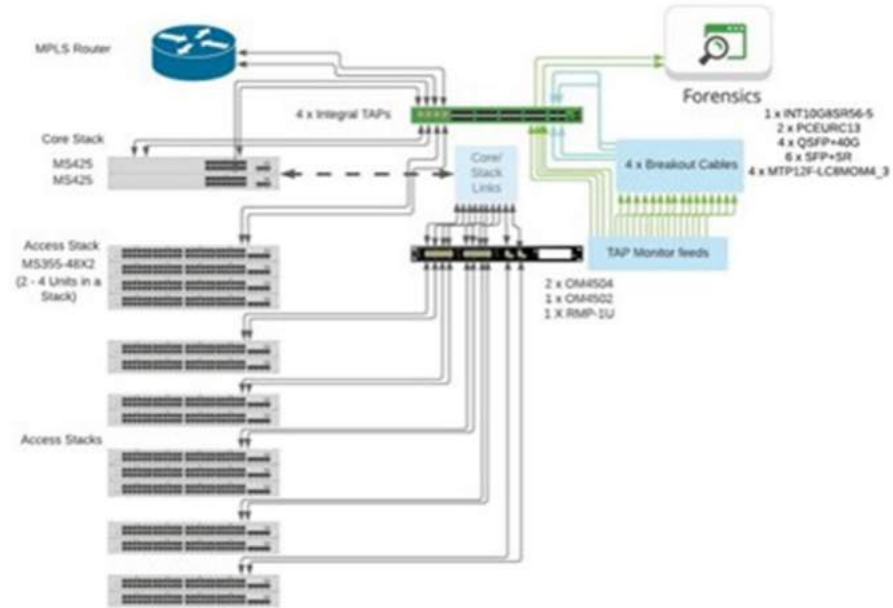

Enterprise Environment

+ Situation

+ Large Healthcare Provider

+ Requirement

+ Implementing a Forescout IDS solution together with Netscout TruView

+ Required visibility of all Router to Switch links

+ Mixture of 10G, 40G and 100G MMF and SMF BiDi

+ Solution

+ Secure passive fibre TAPs

+ High Density 10/40/100G Network Packet Broker

+ Benefit

+ Increased security

+ Visibility between Router and Switches

+ Guaranteed 100% packet visibility

+ Secure Data Diode mirroring of data

+ Reduced cost

+ Extremely cost effective

+ Minimum Space required

+ 2U Space on large sites

+ Operational cost saving

+ No SPAN port management overhead

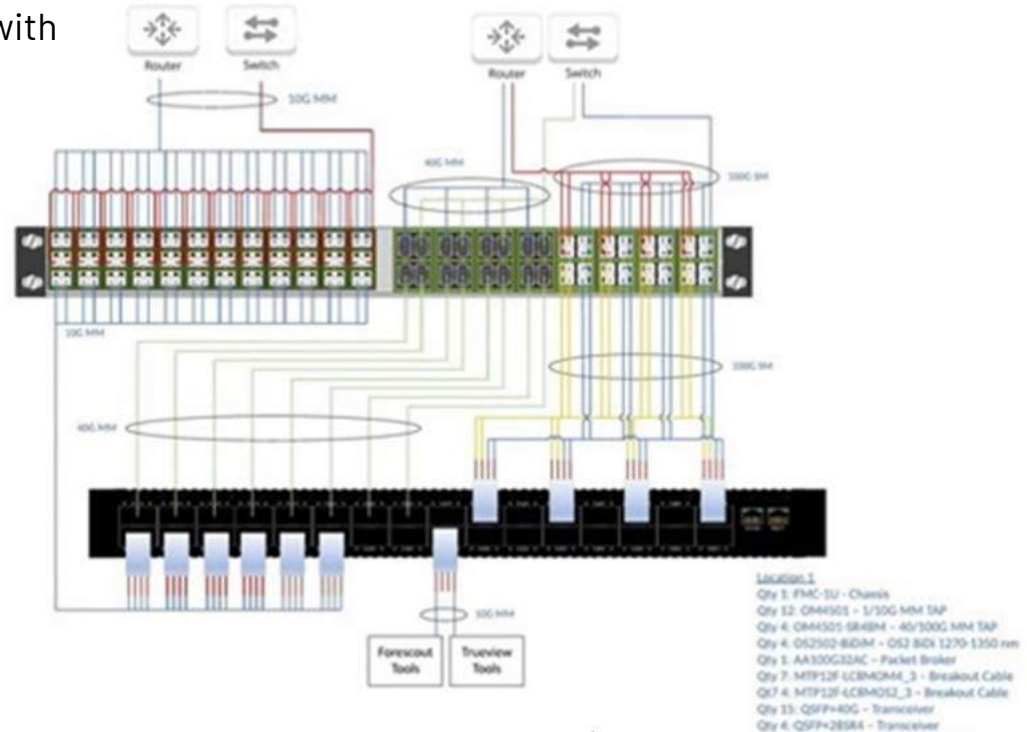

Enterprise Environment

+ Situation

+ Medium Size Finance Customer

+ Requirement

+ Implementing an IDS with capacity for 2x1G links

+ Observe data on 10x1G copper links

+ Solution

+ M1G2ACE chassis with 10 copper Breakout TAPs

+ High Density 1G Network Packet Broker

+ Benefit

+ Increased security

+ Visibility of key links

+ Guaranteed 100% packet visibility

+ Secure Data Diode mirroring of data

+ Investment protection

+ Ability to connect an IDS or another tool via 10G

+ Operational cost saving

+ No SPAN port management overhead

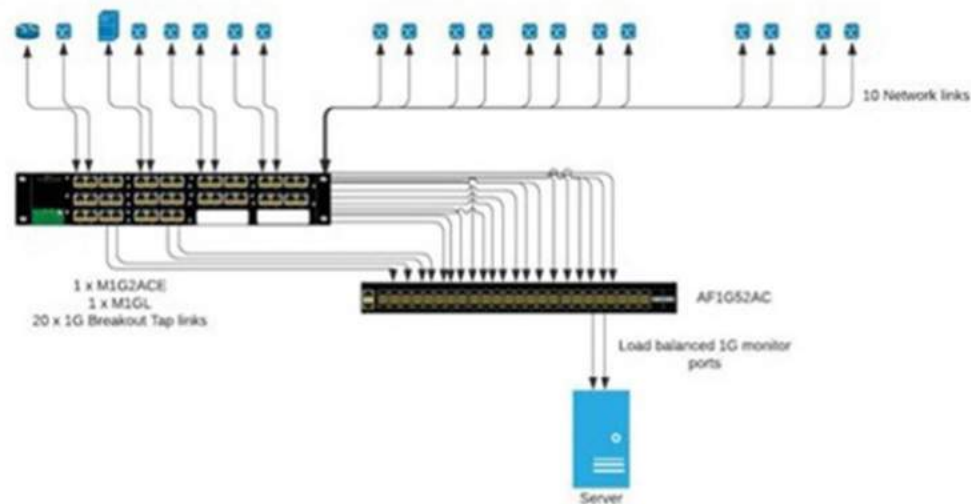

Implementing Inline Visibility Architecture CASE STUDIES

Financial Services

Providing inline threat prevention optimization and analysis

Large investment company looking to optimize threat prevention strategies by adding in-line tool analysis

Solution: Garland's EdgeLens, "Retrospect" transformed network security capabilities with its solution

Allowed to analyze WAF performance to see if it is configured properly or if the threat is missing

- Inline to ensure optimum tool performance
Analysis of packet data before and after device
- Verify all updates or check for threats.
Analyzing why it is not blocked

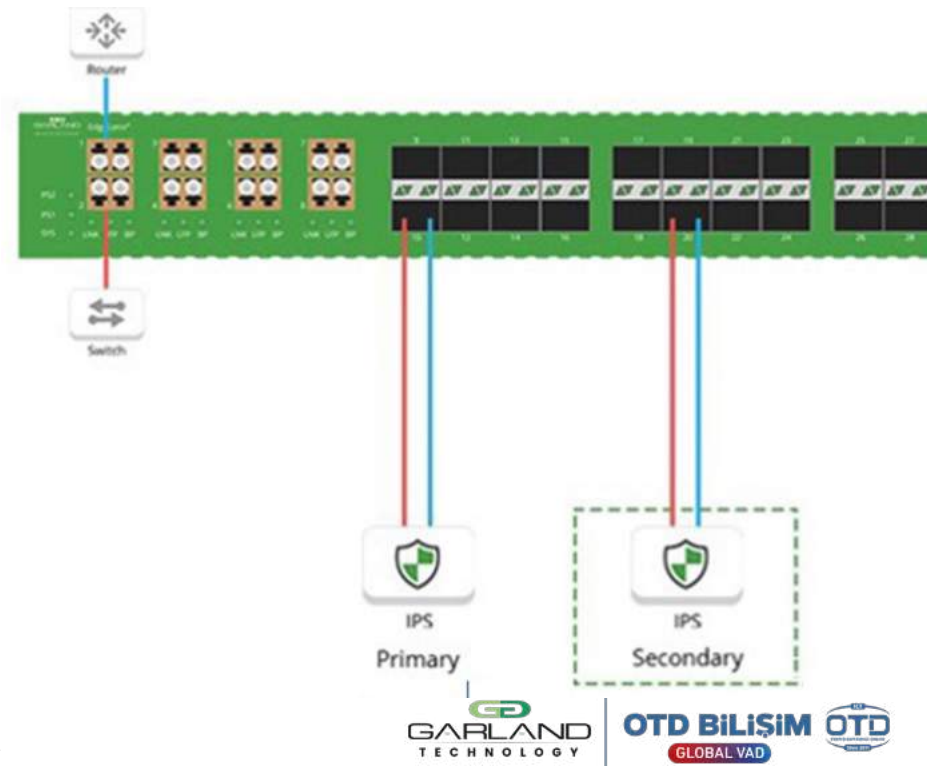

Financial Services

Providing inline threat prevention optimization and analysis

Large investment company looking to optimize threat prevention strategies by reducing in-line vehicle analysis

Solution: Garland's EdgeLens transformed their network security capabilities with the «Historical Look-back» solution

- A primary or "active" IPS
- And a second or "passive" IPS

In case the primary device becomes disabled, the secondary device automatically takes over the primary device.

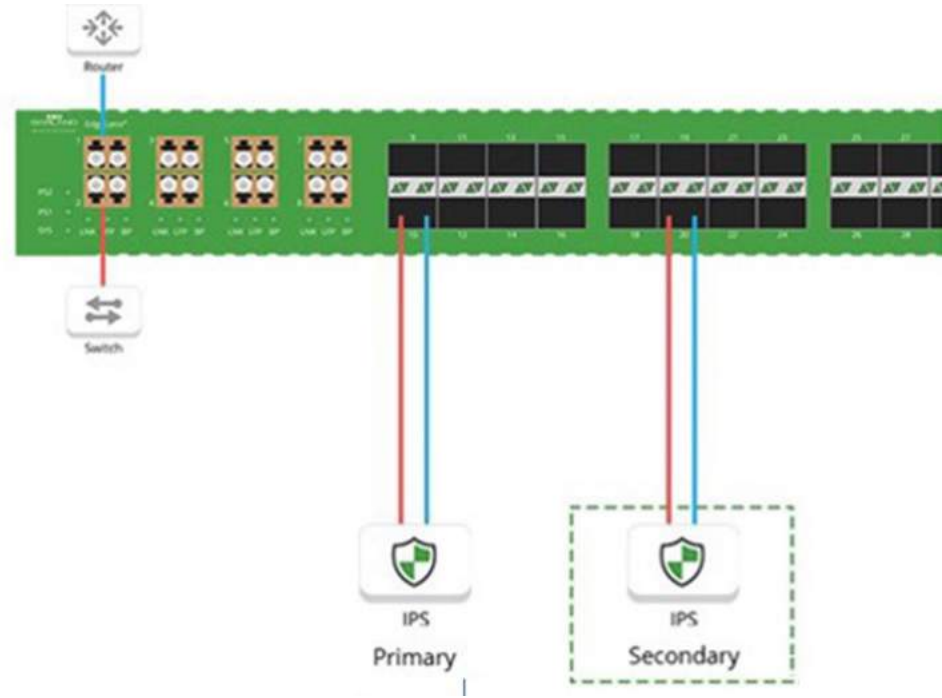

TAP to Tool™ Architecture

Securing and monitoring your network is the ultimate goal

Garland is an enabling technology. Our philosophy is to not lose sight of that goal by architecting to the tool, not competing with them.

TAPs | Foundation of Visibility: Start with Network TAPs

- Provide 100% raw packet data
- Aggregation, regeneration, bypass functionality

Network Packet Brokers: Deploy what you need

- Advanced Aggregation – Filters, Aggregation and load balancing
- Advanced Features – Dedup, packet slicing, time stamping, etc
- Hybrid – Integrated TAPs with packet broker functionality

Tools | Feed your: Network Analyzers, IDS, SSL Decryption, NGFW, Packet capture, APM, IPS, DDoS

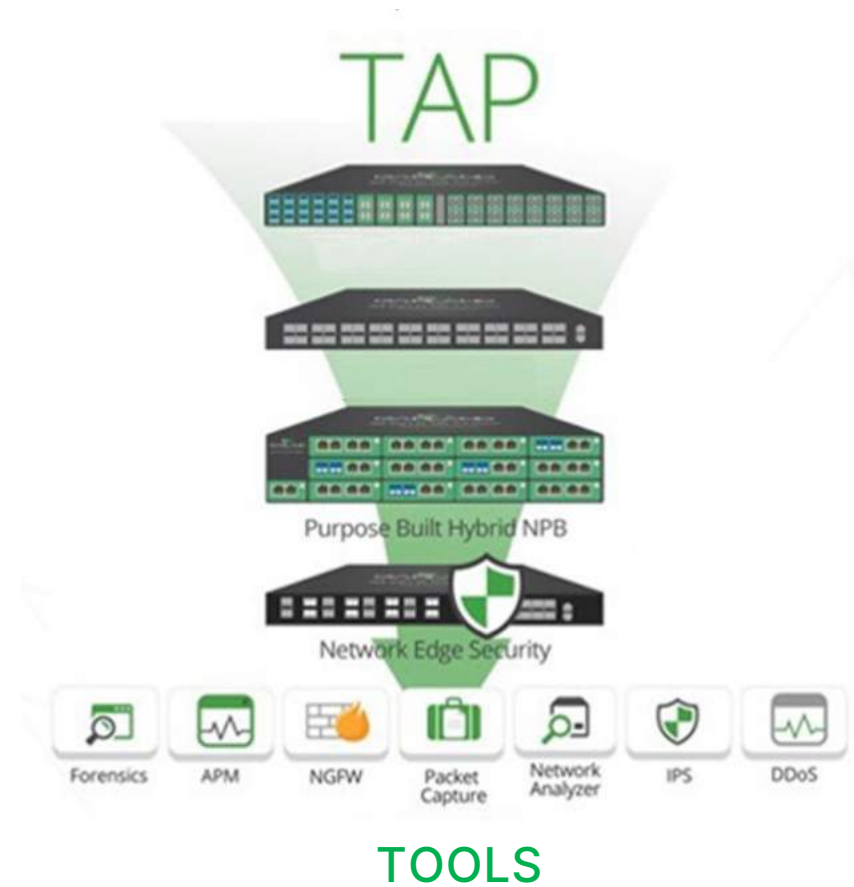

Thank You

